

Tube-Mac[®]

Non-welded Flange Connections

37° Flare and Retain Ring

The standard connection styles offered conform to SAE/ISO flanges along with Tube-Mac[®] proprietary flanges. Other flange patterns may also be available.

There are two methods of attaching the flanges to the pipe

A) Flaring the pipe to 37°

B) Grooving the pipe to accept a retain ring.

The determination of which method to use is based on pressure and flow requirements. The flared system being the most cost effective.

Normally the retain ring system is used for very high pressures and larger heavy wall pipe sizes.

The flanges on both methods can be rotated prior to bolting up thus eliminating the need to be concerned on which axis of the pipe the fitter aligns the flange holes. It also allows at times the flange cap screws to be installed in more confined spaces.

Welding or threading of the flanges to the pipe is eliminated.

INDUSTRY BENEFITS FROM THE FEATURES OF A TUBE-MAC[®] QUALITY ALTERNATIVE PIPING SYSTEM.

Features:

- Qualified customer representatives
- State-of-the-art CAD systems
- World class facilities
- High quality piping and components
- CNC Machining
- Custom Manufacturing
- International Capabilities
- Quality people

Benefits:

- Overall installed cost savings
- Proven leak-free system for over 35 years
- Improved flow characteristics
- Ease of installation
- No welding
- No acid cleaning

Cone and Flange Pressure Ratings and Ordering Information

Flange Size	NB Pipe Size	Part Number O-Ring Face Cone Inserts*	Part Number Flat Face Cone Inserts*	METRIC Tube Size	Part Number O-Ring Face Cone Inserts*	Part Number Flat Face Cone Inserts*	FFCM-34 Flange Pressure Rating SAE Code 61	Bolt Size	FFCM-64 Flange Pressure Rating SAE Code 62	Bolt Size	FFCM-74 Flange Pressure Rating ISO 6164	Bolt Size
1/2" (050)	1/2" SCH 40	CO-SCH40-050	CF-SCH40-050	20 x 2.0	CO-20X2-050	CF-20X2-050	350 bar	M8	420 bar	M8	Not Available	N/A
	1/2" SCH 80	CO-SCH80-050	CF-SCH80-050	20 x 2.5	CO-20X2.5-050	CF-20X2.5-050						
				25 x 2.5	CO-25X2.5-050	CF-25X2.5-050						
				25 x 3.0	CO-25X3-050	CF-25X3-050						
3/4" (075)	3/4" SCH 40	CO-SCH40-075	CF-SCH40-075	20 x 2.0	CO-20X2-075	CF-20X2-075	350 bar	M10	420 bar	M10	Not Available	N/A
	3/4" SCH 80	CO-SCH80-075	CF-SCH80-075	20 x 2.5	CO-20X2.5-075	CF-20X2.5-075						
				25 x 2.5	CO-25X2.5-075	CF-25X2.5-075						
				25 x 3.0	CO-25X3-075	CF-25X3-075						
				30 x 3.0	CO-30X3-075	CF-30X3-075						
1" (100)	1" SCH 40	CO-SCH40-100	CF-SCH40-100	25 x 2.5	CO-25X2.5-100	CF-25X2.5-100	350 bar	M10	420 bar	M12	Not Available	N/A
	1" SCH 80	CO-SCH80-100	CF-SCH80-100	25 x 3.0	CO-25X3-100	CF-25X3-100						
				30 x 3.0	CO-30X3-100	CF-30X3-100						
				30 x 4.0	CO-30X4-100	CF-30X4-100						
				38 x 4.0	CO-38X4-100	CF-38X4-100						
1-1/4" (125)	1-1/4" SCH 40	CO-SCH40-125	CF-SCH40-125	30 x 3.0	CO-30X3-125	CF-30X3-125	275 bar	M10	420 bar	M12	Not Available	N/A
	1-1/4" SCH 80	CO-SCH80-125	CF-SCH80-125	30 x 4.0	CO-30X4-125	CF-30X4-125						
				38 x 4.0	CO-38X4-125	CF-38X4-125						
				38 x 5.0	CO-38X5-125	CF-38X5-125						
				42 x 4.0	CO-42X4-125	CF-42X4-125						
1-1/2" (150)	1-1/2" SCH 40	CO-SCH40-150	CF-SCH40-150	38 x 4.0	CO-38X4-150	CF-38X4-150	210 bar	M12	420 bar	M16	Not Available	N/A
	1-1/2" SCH 80	CO-SCH80-150	CF-SCH80-150	38 x 5.0	CO-38X5-150	CF-38X5-150						
	1-1/2" SCH 160	CO-SCH160-150	CF-SCH160-150	42 x 4.0	CO-42X4-150	CF-42X4-150						
				50 x 5.0	CO-50X5-150	CF-50X5-150						
2" (200)	2" SCH 40	CO-SCH40-200	CF-SCH40-200	50 x 5.0	CO-50X5-200	CF-50X5-200	210 bar	M12	420 bar	M20	400 bar	M16
	2" SCH 80	CO-SCH80-200	CF-SCH80-200	60 x 5.0	CO-60X5-200	CF-60X5-200						
	2" SCH 160	CO-SCH160-200	CF-SCH160-200	60 x 6.0	CO-60X6-200	CF-60X6-200						
2-1/2" (250)	2-1/2" SCH 40	CO-SCH40-250	CF-SCH40-250	60 x 5.0	CO-60X5-250	CF-60X5-250	175 bar	M12	Not Available	N/A	400 bar	M20
	2-1/2" SCH 80	CO-SCH80-250	CF-SCH80-250	73 x 5.0	CO-73X5-250	CF-73X5-250						
	2-1/2" SCH 160	CO-SCH160-250	CF-SCH160-250	73 x 7.0	CO-73X7-250	CF-73X7-250						
				75 x 5.0	CO-75X5-250	CF-75X5-250						
				75 x 7.0	CO-75X7-250	CF-75X7-250						
3" (300)	3" SCH 40	CO-SCH40-300	CF-SCH40-300	73 x 5.0	CO-73X5-300	CF-73X5-300	140 bar	M16	Not Available	N/A	400 bar	M24
	3" SCH 80	CO-SCH80-300	CF-SCH80-300	73 x 7.0	CO-73X7-300	CF-73X7-300						
				75 x 5.0	CO-75X5-300	CF-75X5-300						
				75 x 7.0	CO-75X7-300	CF-75X7-300						
				90 x 5.0	CO-90X5-300	CF-90X5-300						
			90 x 7.0	CO-90X7-300	CF-90X7-300							
3-1/2" (350)	3-1/2" SCH 40	CO-SCH40-350	CF-SCH40-350	100 x 6.0	CO-100X6-350	CF-100X6-350	35 bar	M16	Not Available	N/A	400 bar	N/A
	3-1/2" SCH 80	CO-SCH80-350	CF-SCH80-350	100 x 8.0	CO-100X8-350	CF-100X8-350						
4" (400)	4" SCH 40	CO-SCH40-400	CF-SCH40-400	115 x 6.0	CO-115X6-400	CF-115X6-400	35 bar	M16	Not Available	N/A	400 bar	M30
	4" SCH 80	CO-SCH80-400	CF-SCH80-400	115 x 8.0	CO-115X8-400	CF-115X8-400						

* Add -SS for Stainless Steel Parts

To order flanges, use the Flange part number followed by the size designator.
For example a 2" FFCM-34 flange would be "FFCM-34-200"

TUBE/PIPE PRESSURE RATINGS MAY BE LOWER THAN FLANGE RATINGS. PROPER TUBE/PIPE SELECTION IS REQUIRED

Tube-Mac[®]

37° Flare

Method A: Flare Connection

METHOD A (FLARED SYSTEM)

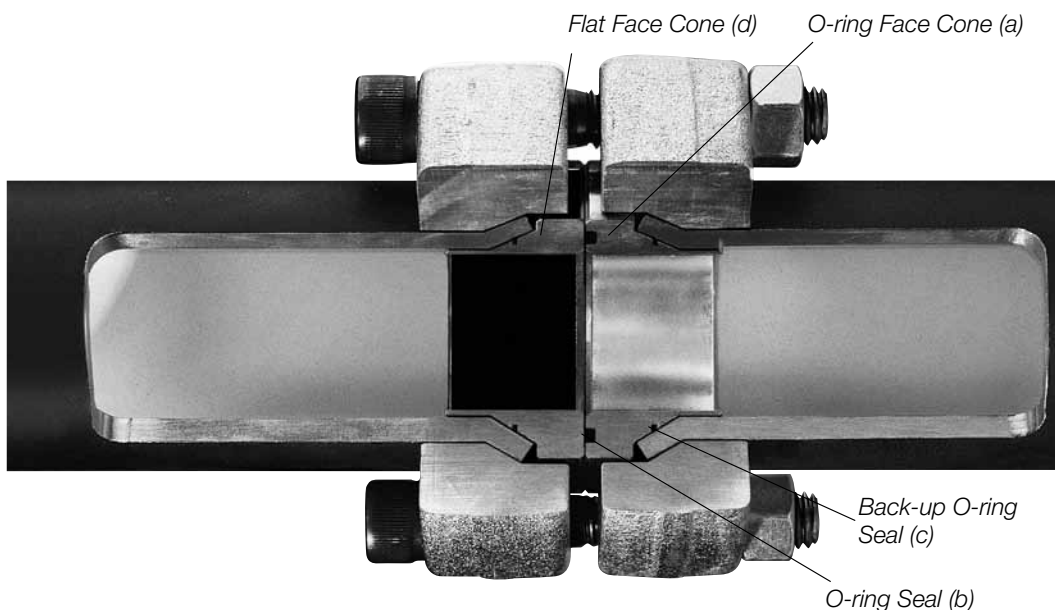

METHOD A:

The flared configuration is based on flaring the pipe ends to 37° and utilising two internal cones. O-ring face cone (a) with o-ring seal (b) and Flat face cone (d). Both internal cones have back-up o-rings (c).

The flange is slipped onto the pipe before flaring, after flaring the cone is located into the pipe. Bolting the connection together draws the flared pipe and cone in contact with each other providing an elastomer seal at the flare and at the face.

FLARE CONNECTION FEATURES

- Size range 1/2" to 4" NB
- Sizes up to 8" available on request
- Metric sizes available
- Pressures to 414 bar (6000 psi)
- Safety Factor - min. 3:1

**Maximum allowable working pressures are based on the lower of the pipe rating per ANSI B31.3 or the connection rating. (Stainless Steel Optional)*

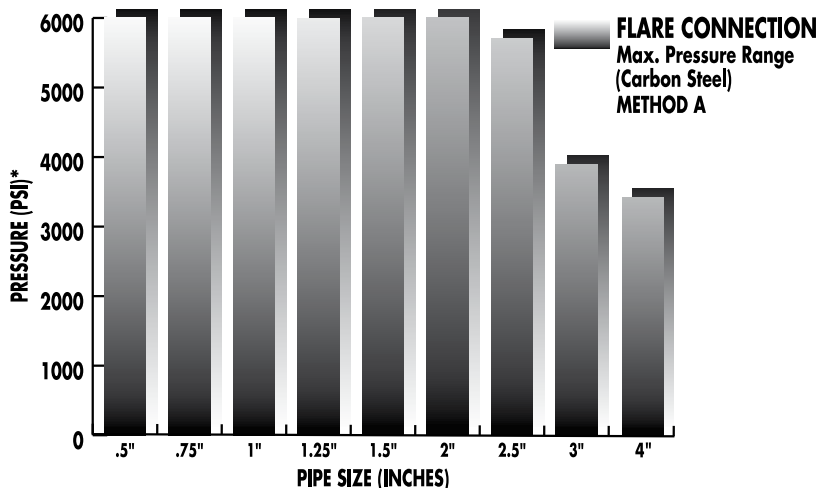

Tube-Mac®

Retain Ring

Method B: Retain Ring Connection

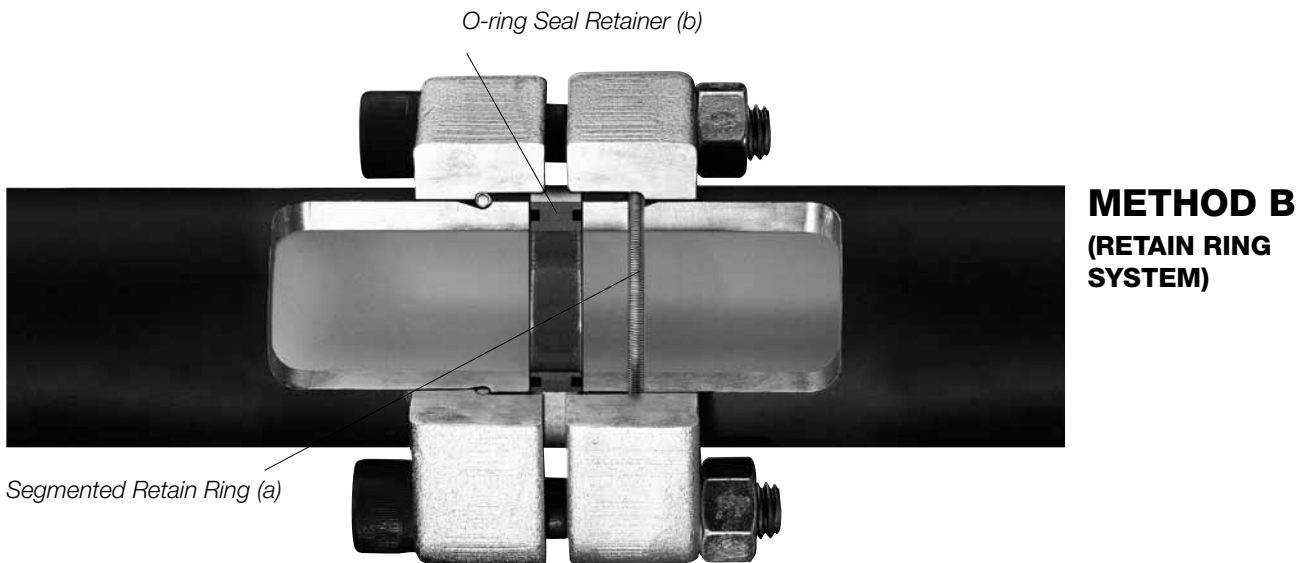

METHOD B:

The retain ring configuration uses heavy wall pipe and has a machined butt end face, along with an annular groove on the outside diameter.

After machining, the flange is slipped onto the pipe and a retain ring (a) which consists of a segmented stainless steel ring bound by a spiral wound stainless steel spring is sprung over the outside diameter of the pipe, nesting in the annular groove. Bolting the connection together draws the flanges against the retain rings with the o-ring seal retainer (b) captive within the connection.

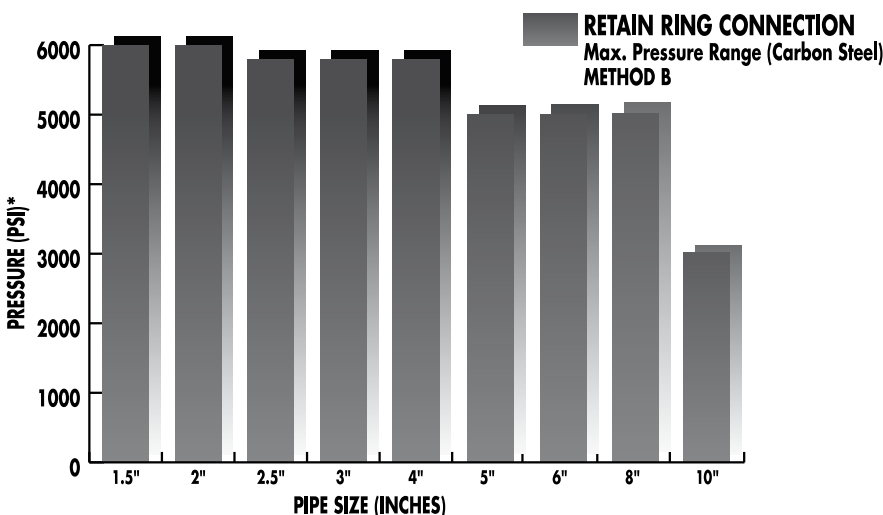

RETAIN RING CONNECTION FEATURES

- Size range 1-1/2" to 10" NB
- Metric sizes available
- Pressures to 414 bar (6000 psi)
- Safety Factor - min. 3:1

**Maximum allowable working pressures are based on the lower of the pipe rating per ANSI B31.3 or the connection rating. (Stainless Steel Optional)*