

# PROCHEM

Stainless Steel Specialists

*Product solutions for a world of difference*

INSTRUMENTATION

**GYROLOK®**



PIPING PRODUCTS



INSTRUMENTATION



VALVES AND ACTUATORS



MANUFACTURING



INDENT SERVICE



HYDRAULIC



# GYROLOK®



**HOKE® manufactured GYROLOK® tube fittings have been carefully designed and manufactured to provide a wide range of outstanding leak-tight application capabilities.**

**MANUFACTURED BY**



## GYROLOK® to Tube Union



## GYROLOK® to Male Pipe

HOKE® has built a first-class reputation for designing and manufacturing state-of-the-art products. In striving for maximum quality and value, HOKE® has set the industry standards for product safety, operability, durability and reliability.

HOKE® manufactured GYROLOK® fittings are available as standard in brass, 316 Stainless Steel and Monel® 400. Also available for custom orders in special shapes and materials:

Hastelloy® C276:	HC
Duplex:	DX3
Super Duplex:	D50
6Mo (UNS S31254):	6MO
Inconel® 600:	INC
Inconel® 625:	625
Incoloy® 825:	825
Titanium:	Ti

*Monel, Hastelloy, Inconel and Incoloy are registered trademarks.*

# Twin Ferrule

GYROLOK® to Female Pipe



GYROLOK® Stub  
Connectors/Adaptors



GYROLOK® to Welded Systems

## Tube Fittings

### GYROLOK®

#### Pressure Rating

GYROLOK® fitting ends are rated for working pressures higher than the tubing recommended for use with GYROLOK® fittings. Tubing should not be utilised at pressures above its maximum allowable working pressures. Check the GYROLOK® Tubing Data Charts for specific information. If no pressure is identified for a given size and wall thickness of tubing, that tubing is not considered suitable for use with tube fittings. Pressure ratings may vary for other fitting ends, such as NPT or O-ring seal.

#### Vacuum Rating

GYROLOK® offers deep vacuum capability. With good quality tubing, GYROLOK® fittings will be leak-tight at vacuum levels at  $10^{-9}$  torr while tested with a leakage sensitivity of  $10^{-9}$  sccs.

#### Temperature

GYROLOK® fittings provide safe, reliable performance from cryogenic temperatures to high temperature bake out levels, depending on material.

- 316 Stainless Steel: -200 to 426°C (-325 to 800°F)
- Brass (copper tubing): -200 to 203°C (-325 to 400°F)
- Monel®: -200 to 426°C (-325 to 800°F)
- Nylon: -53 to 65°C (-65 to 150°F)

CAUTION (For Stainless Steel): Intermittent use to 649°C (1200°F) is possible, however prolonged exposure to temperatures over 426°C (800°F) is not recommended.

CAUTION (For Nylon): Material strength decreases rapidly as temperature increases (e.g. allowable pressure at 100°C (212°F) is approximately 40% of allowable pressure at 24°C (75°F).)

#### Training and Engineering Support

We can train every one of your trades people to make sure each understands how a GYROLOK® fitting functions. By teaching the proper tubing preparation and installation procedures, we ensure maximum product performance.

We take the time to assist our customers in finding the GYROLOK® fitting that is right for their specific needs. Contact Prochem for more of our informative support materials and catalogues.

*Monel is a registered trademark.*

# GYROLOK®

GYROLOK®

GYROLOK® to 37° Flare (AN)

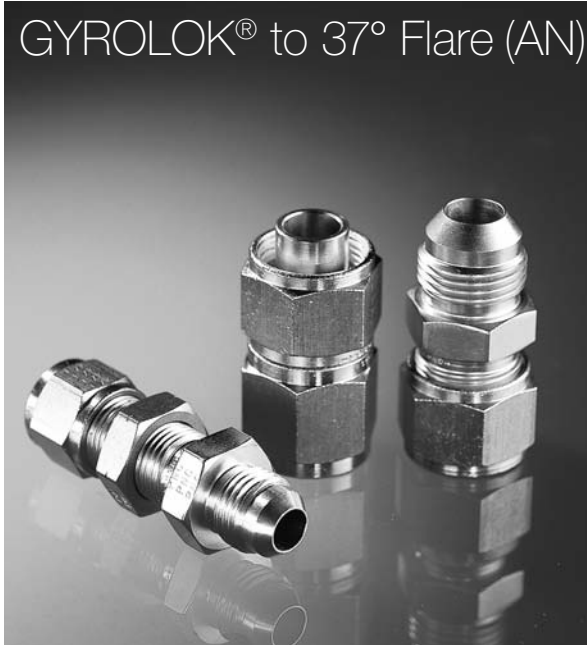

GYROLOK® Cap and Plug



GYROLOK® Components



Safety Changer Ferrule & Safety Changer Nut & Ferrule



# GYROLOK®



GYROLOK® RT & RS

GYROLOK® to O-Ring Seal & Tube to SAE/MS



GYROLOK® Specials



## Count on HOKE® Safety

We pride ourselves on our solid commitment to safety. HOKE® manufactured products are machined with total precision, for a long life and maximum performance. Standard materials include 316 Stainless Steel, Brass and Monel®. Hastelloy® C276, Duplex, Super Duplex, 6Mo (UNS S31254), Inconel®, Incoloy® and Titanium, are used to meet special customer requirements. Each product is manufactured to resist the detrimental effects of corrosion, and to withstand extreme pressures or vacuum conditions, as well as temperatures ranging from cryogenic -198 to 648°C (-325 to 1200°F).

HOKE® manufactured products meet the most stringent standards for safety, reliability and quality: AGA (American Gas Association), ANSI (American National Standards Institute), ASME (American Society of Mechanical Engineers), ASTM (American Society for Testing and Materials), MSS (Manufacturers Standardization Society) and NACE (National Association of Corrosion Engineers).

As a result, HOKE® manufactured products are the choice of OEMs, refiners, chemical manufacturers and all those whose primary concern is safe, reliable performance.

If you have any questions about the design specifications of HOKE® manufactured products, contact Prochem.

*Monel, Hastelloy, Inconel and Incoloy are registered trademarks.*



# GYROLOK®

## Quick Reference Guide

**UAN UNION, BUAN BULKHEAD AN UNION AND AAN AN ADAPTOR**



**AF ADAPTOR FEMALE**



**U UNION**



**RU REDUCING UNION**



**BA BULKHEAD ADAPTOR**



**R REDUCER**



**BU BULKHEAD UNION**



**TTT UNION TEE**



**AM ADAPTOR MALE**



**PC PORT CONNECTOR & PC REDUCING PORT CONNECTOR**



**LU UNION ELBOW**



**C UNION CROSS**



**HYDRAULIC PRE-SETTING TOOL**



**CM CONNECTOR MALE**



**LM ELBOW MALE**



**TMT MALE RUN TEE**



**TTM MALE BRANCH TEE**



**QUICK COUPLERS**



**BCM BULKHEAD MALE CONNECTOR**



**LMF 45D MALE ELBOW**



# TWIN FERRULE TUBE FITTINGS

**CF CONNECTOR FEMALE**



**LF ELBOW FEMALE**



**N NUT**



**BN BULKHEAD NUT**



**TFT FEMALE RUN TEE**



**TTF FEMALE BRANCH TEE**



**KN KNURLED NUT**



**SCRN SCREEN**



**BCF BULKHEAD CONNECTOR FEMALE**



**CP TUBE CAP**



**FF FRONT FERRULE**



**FR REAR FERRULE**



**P PLUG**



**CLF LAPPED FLANGE CONNECTOR**



**SCF SAFETY CHANGER FERRULE**



**SCNF SAFETY CHANGER NUT & FERRULE**



**EZ (G SERIES) GYROLOK®**



**EC (BSPT) GYROLOK®**



**FCRF INTEGRAL FLANGE**



**GYROGAGE**



**EA (G SERIES) GYROLOK®**



**FTC FUSABLE PLUG**



**DI DIELECTRIC FITTING**



**GMT GYROLOK® MARKING TOOL**



# GYROLOK®

HAND ASSEMBLED

FULLY ASSEMBLED FITTING AND TUBE

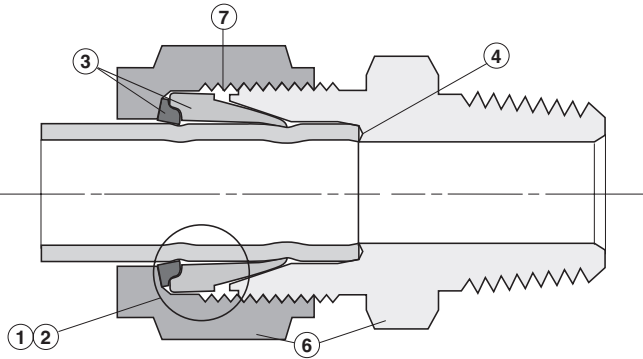
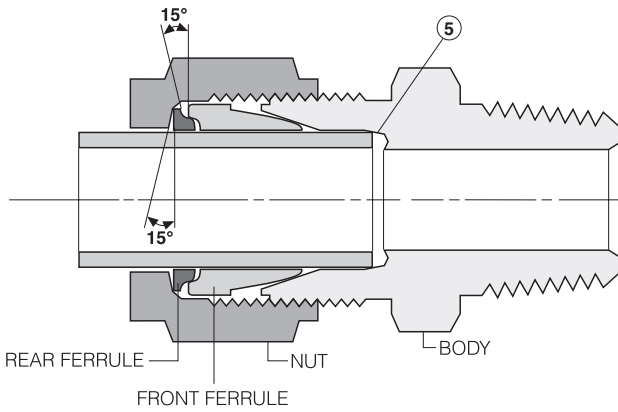

MANUFACTURED BY



**THE GYROLOK® DESIGN**

GYROLOK® Tube Fittings have been carefully designed and manufactured to provide a wide range of outstanding leak-tight application capabilities.

**Materials**

GYROLOK® fittings are available as standard in Brass, 316 Stainless Steel and Monel®:

- 316 Stainless Steel Forgings: ASTM A-182
- 316 Stainless Steel Bar Stock: ASTM A-479
- Brass Forgings, Alloy 377: QQ-B-626
- Brass Bar Stock, Alloy 353: ASTM B-453
- Brass Bar Stock, Alloy 360: QQ-B-626
- Monel® Forgings, Alloy 400: QQ-N-281
- Monel® Bar Stock, Alloy 405: QQ-N-281
- Monel® Bar Stock, Alloy K500: QQ-N-286

GYROLOK® fittings are also available for custom orders in special shapes and special materials:

- Hastelloy® C276: HC
- Duplex: DX3
- Super Duplex: D50
- 6Mo (UNS S31254): 6MO
- Inconel® 600: INC
- Inconel® 625: 625
- Incoloy® 825: 825
- Titanium: Ti

Contact Prochem for further information.

**Certified Material Test Reports (CMTRs)**

Bodies and nuts of GYROLOK® fittings in all materials other than Brass are heat code traceable. To obtain CMTRs for these components, place separate orders for such items and specify "CMTRs required on all items".

*Monel, Hastelloy, Inconel and Incoloy are registered trademarks.*

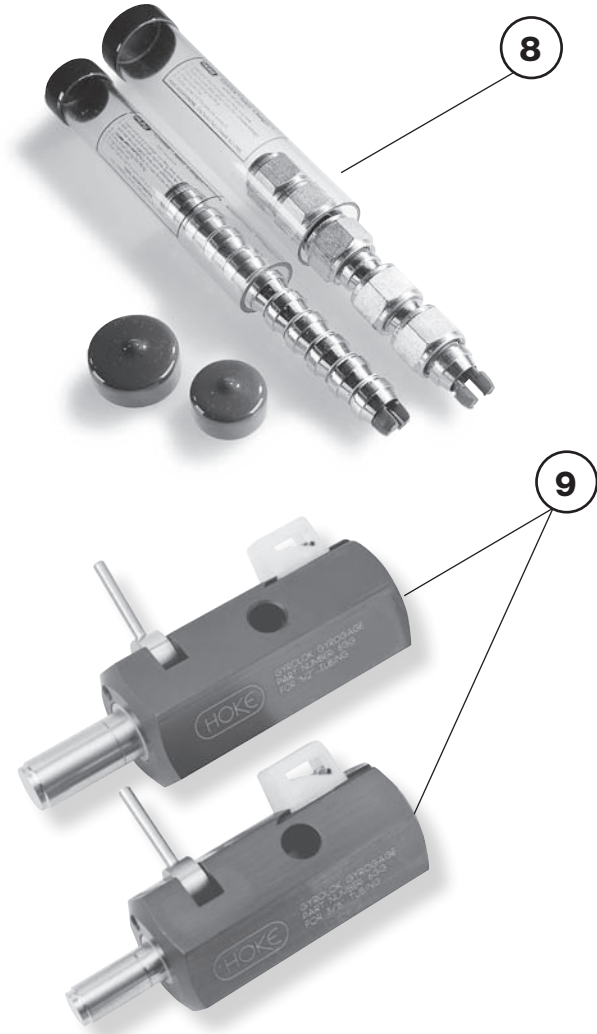







# Features AND Benefits

**FEATURES**

**BENEFITS**

<p><b>1</b> CONTROLLED FERRULE DRIVE</p> 	<p><b>Roll-in locking action of rear ferrule:</b> During fitting makeup, 15° angles close – between the rear ferrule and nut, and between the rear ferrule and front ferrule – thus preventing overstressing of tubing or excessively reducing tubing’s inside diameter.</p> <p><b>Front ferrule shoulder:</b> Front ferrule shoulder prevents body expansion and nut jamming, caused by overtightening.</p>	<p>Provides maximum user safety under high pressure/vibration conditions. Prevents overstressing, which causes tubing failure and possible injury. System efficiency is improved by maximising flow.</p> <p>Provides unmatched remake life. Maximises value and economy.</p>
<p><b>2</b> HOKE® VALVES WITH INTEGRAL GYROLOK® END FITTINGS</p> 	<p>Controlled ferrule drive prevents end connection expansion, thus prolonging valve life and eliminating the need to use female ended valves with separate fittings. Eliminates a possible leak path and extends valve life.</p>	<p>Long product life and maximum value. Safety and economy.</p>
<p><b>3</b> STAINLESS STEEL FERRULE MANUFACTURE</p>	<p>Front ferrules – no surface treatment in any size. Rear ferrules – no surface treatment in sizes 1/2" (12 mm) and under. Sizes over 1/2" (12 mm) treated and plated.</p>	<p>Increased resistance to media and atmospheric corrosion extends product life and user safety.</p>
<p><b>4</b> BUTT SEAL</p> 	<p>Provides a second, series seal and eliminates dead space.</p>	<p>Maximises fitting leak integrity and user safety. Can seal with scratched tubing. Increases accuracy in sampling applications. Reduces pump-down time in vacuum applications.</p>
<p><b>5</b> SIZING ANGLE</p>	<p>Slight taper in the tube socket’s base of the fitting body reduces possibility of tube sticking.</p>	<p>Less tube sticking during disassembly saves time and money.</p>
<p><b>6</b> MATERIAL TRACEABILITY ON FITTING BODY AND NUT</p>	<p>Bodies and nuts made of 316 Stainless Steel, Monel® and special materials are heat code traceable to Certified Material Test Reports. <i>Monel is a registered trademark.</i></p>	<p>Traceability provides added safety. Certified Material Test Reports are available for review and verification.</p>
<p><b>7</b> SILVER-PLATED NUT THREADS</p>	<p>Silver plating extends fitting life by preventing galling, up to 1200°C.</p>	<p>Extended product life at extreme temperatures.</p>
<p><b>8</b> GYROLOK® SAFETY CHANGER NUT &amp; FERRULE SETS</p>	<p>Nut and ferrule sets supplied on rods, already correctly oriented. (Not necessary to handle ferrules when replacing components.)</p>	<p>Safest, simplest device for component replacement.</p>
<p><b>9</b> GYROGAGE &amp; GYROLOK® MARKING TOOL</p> 	<p>Marks tubing to show that tubing has been properly inserted into fitting, and that fitting has been properly tightened.</p>	<p>Maximum safety resulting from ability to verify correct tube insertion and proper tightening.</p>





**FOR FURTHER DETAILS PLEASE CONTACT YOUR LOCAL PROCHEM OFFICE**

**ADELAIDE**

3A CB Fisher Drive  
CAVAN SA 5094

**Telephone 61-8-8241 7633**  
adesales@prochem.com.au

**HOBART**

96-98 Central Avenue  
Derwent Park TAS 7009

**Telephone 61-3-6272 8828**  
hobsales@prochem.com.au

**PERTH**

6 Forge Street  
Welshpool WA 6106

**Telephone 61-8-9458 7777**  
persales@prochem.com.au

**BRISBANE**

1-5 Kingsbury Street  
Brendale QLD 4500

**Telephone 61-7-3265 2711**  
brisales@prochem.com.au

**MELBOURNE**

5-15 Ventura Place  
Dandenong South VIC 3175

**Telephone 61-3-9799 2244**  
melsales@prochem.com.au

**SYDNEY**

30 Enterprise Circuit  
Prestons NSW 2170

**Telephone 61-2-9727 0044**  
sydsales@prochem.com.au

[www.prochem.com.au](http://www.prochem.com.au)