

PROCHEM

Your Source for Local Supply and Support

PIPING PRODUCTS
HYGIENIC



PIPING PRODUCTS



INSTRUMENTATION



VALVES AND ACTUATORS



MANUFACTURING



INDENT SERVICE



HYDRAULIC



BSM



BSM RJT Standard

CF8 = 304 STAINLESS STEEL,
CF8M = 316 STAINLESS STEEL
ALL DIMENSIONS ARE IN MILLIMETRES

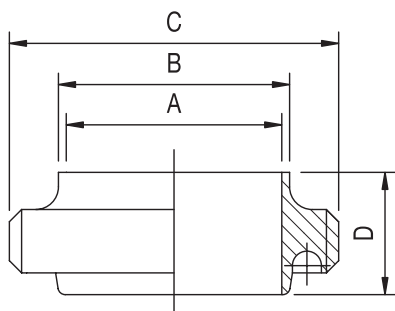
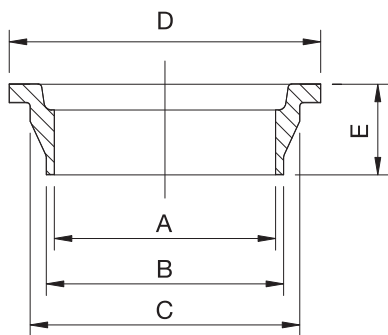
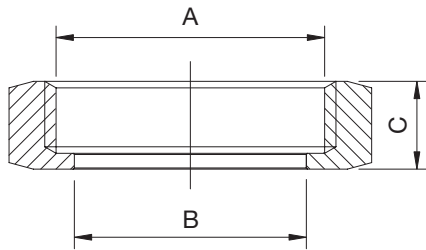
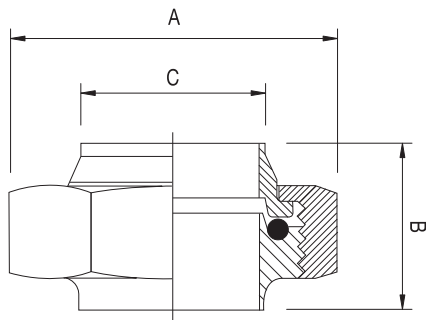

BSM RJT COMPLETE UNION

Part Number	Size	A	B*	C	A/F
BSMBUWE025AI	25.4	59	41	25.4	50.8
BSMBUWE038AI	38.1	75	41	38.1	65.0
BSMBUWE051AI	50.8	92	41	50.8	79.4
BSMBUWE063AI	63.5	107	41	63.5	92.1
BSMBUWE076AI	76.2	121	41	76.2	104.8
BSMBUWE102AI	101.6	151	41	101.6	130.2
BSMBUWE152AI	152.4	213	49	152.4	184.0

* Compressed condition

BSM RJT HEX NUT CF8

Part Number	Size	A	B	C
BSMNH025CI	25.4	42.3 x 8TPI WHIT	33.3	22
BSMNH038CI	38.1	55.0 x 8TPI WHIT	46.0	22
BSMNH051CI	50.8	67.8 x 6TPI WHIT	58.7	22
BSMNH063CI	63.5	80.5 x 6TPI WHIT	71.4	22
BSMNH076CI	76.2	93.2 x 6TPI WHIT	84.1	22
BSMNH102CI	101.6	118.6 x 6TPI WHIT	109.5	22
BSMNH152CI	152.4	169.4 x 6TPI WHIT	160.3	24

BSM RJT LINER CF8M

Part Number	Size	A	B	C	D	E
BSMWL025AI	25.4	22.2	25.4	32.4	41.3	19
BSMWL038AI	38.1	34.9	38.1	45.1	54.0	19
BSMWL051AI	50.8	47.6	50.8	57.8	66.7	19
BSMWL063AI	63.5	60.3	63.5	70.5	79.4	19
BSMWL076AI	76.2	73.0	76.2	83.1	92.1	19
BSMWL102AI	101.6	98.4	101.6	108.6	117.5	19
BSMWL152AI	152.4	149.2	152.4	159.4	168.3	27

BSM RJT MALE PART CF8M

Part Number	Size	A	B	C	D
BSMBM025AI	25.4	22.2	25.4	45.7 x 8TPI WHIT	26.8
BSMBM038AI	38.1	34.9	38.1	58.4 x 8TPI WHIT	26.8
BSMBM051AI	50.8	47.6	50.8	72.7 x 6TPI WHIT	26.8
BSMBM063AI	63.5	60.3	63.5	85.4 x 6TPI WHIT	26.8
BSMBM076AI	76.2	73.0	76.2	98.1 x 6TPI WHIT	26.8
BSMBM102AI	101.6	98.4	101.6	123.5 x 6TPI WHIT	26.8
BSMBM152AI	152.4	149.2	152.4	174.3 x 6TPI WHIT	26.8



BSM RJT SEAL (O-RING) EPDM

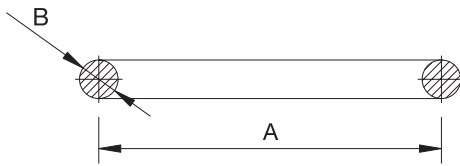

Part Number	Size	A	B
BSMOR025E	25.4	33.3	6.5
BSMOR038E	38.1	46.0	6.5
BSMOR051E	50.8	58.7	6.5
BSMOR063E	63.5	71.4	6.5
BSMOR076E	76.2	84.1	6.5
BSMOR102E	101.6	109.5	6.5
BSMOR152E	152.4	160.3	6.5

BSM RJT CIP SEAL (O-RING) EPDM

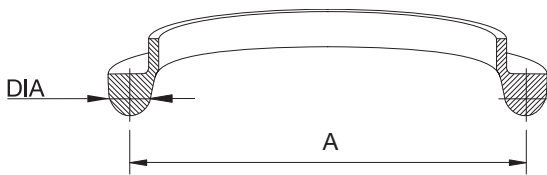

Part Number	Size	A	B
BSMORC025E	25.4	33.3	6.5
BSMORC038E	38.1	46.0	6.5
BSMORC051E	50.8	58.7	6.5
BSMORC063E	63.5	71.4	6.5
BSMORC076E	76.2	84.1	6.5
BSMORC102E	101.6	109.5	6.5
BSMORC152E	152.4	160.3	6.5

Seals also available in Teflon®, Viton® and Buna N

BSM RJT BLANK CAPS 316

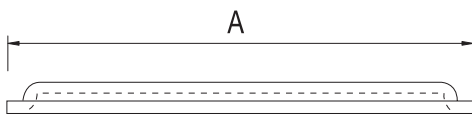

Part Number	Size	A
BSMCB025A	25.4	41.3
BSMCB038A	38.1	54.0
BSMCB051A	50.8	66.7
BSMCB063A	63.5	79.4
BSMCB076A	76.2	92.1
BSMCB102A	101.6	117.5
BSMCB152A	152.4	168.3

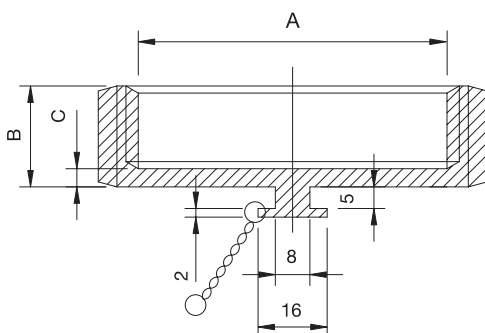

BSM RJT BLANK HEX NUT CF8 C/W CHAIN

Part Number	Size	A	B	C
BSMNB025CI	25.4	42.3 x 8TPI WHIT	22	4
BSMNB038CI	38.1	55.0 x 8TPI WHIT	22	4
BSMNB051CI	50.8	67.8 x 6TPI WHIT	22	4
BSMNB063CI	63.5	80.5 x 6TPI WHIT	22	4
BSMNB076CI	76.2	93.2 x 6TPI WHIT	22	4
BSMNB102CI	101.6	118.6 x 6TPI WHIT	22	4

BSM Flat-Faced

CF8 = 304 STAINLESS STEEL,
CF8M = 316 STAINLESS STEEL
ALL DIMENSIONS ARE IN MILLIMETRES

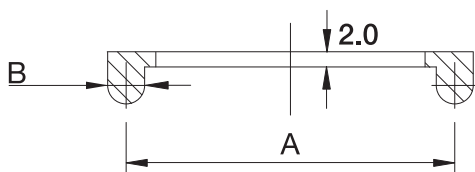
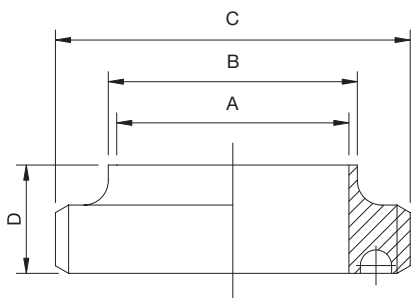
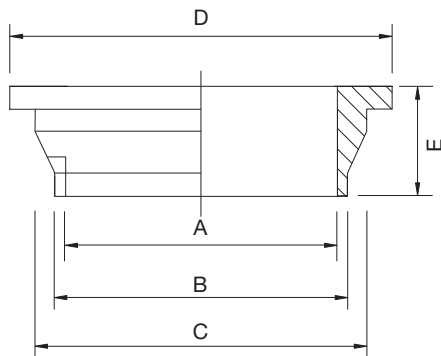
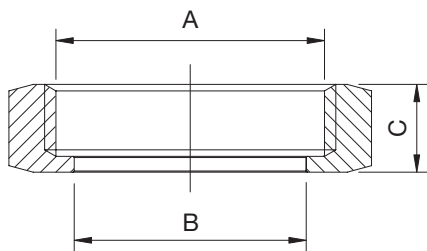
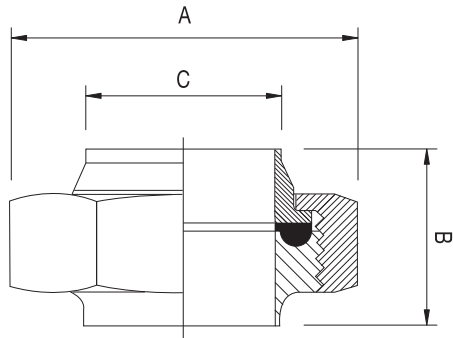

BSM FLAT-FACED COMPLETE UNION

Part Number	Size	A	B*	C	A/F
BSMFFBUWE025AI	25.4	59	43.2	25.4	50.8
BSMFFBUWE038AI	38.1	75	43.2	38.1	65.0
BSMFFBUWE051AI	50.8	92	43.2	51.8	79.4
BSMFFBUWE063AI	63.5	107	43.2	63.5	92.1
BSMFFBUWE076AI	76.2	121	43.2	76.8	104.8
BSMFFBUWE102AI	101.6	151	43.2	101.6	130.2
BSMFFBUWE152AI	152.4	213	51.2	152.4	184.0

* Uncompressed condition

BSM FLAT-FACED HEX NUT CF8

Part Number	Size	A	B	C
BSMNH025CI	25.4	42.3 x 8TPI WHIT	33.3	22
BSMNH038CI	38.1	55.0 x 8TPI WHIT	46.0	22
BSMNH051CI	50.8	67.8 x 6TPI WHIT	58.7	22
BSMNH063CI	63.5	80.5 x 6TPI WHIT	71.4	22
BSMNH076CI	76.2	93.2 x 6TPI WHIT	84.1	22
BSMNH102CI	101.6	118.6 x 6TPI WHIT	109.5	22
BSMNH152CI	152.4	169.4 x 6TPI WHIT	160.3	24

BSM FLAT-FACED LINER CF8M

Part Number	Size	A	B	C	D	E
BSMFFWL025AI	25.4	22.2	25.4	32.6	41.3	19
BSMFFWL038AI	38.1	34.9	38.1	45.3	54.0	19
BSMFFWL051AI	50.8	47.6	50.8	58.0	66.7	19
BSMFFWL063AI	63.5	60.3	63.5	70.7	79.4	19
BSMFFWL076AI	76.2	73.0	76.2	83.4	92.1	19
BSMFFWL102AI	101.6	98.4	101.6	108.8	117.5	19
BSMFFWL152AI	152.4	149.2	152.4	159.6	168.3	27

BSM FLAT-FACED MALE PART CF8M

Part Number	Size	A	B	C	D
BSMFFBM025AI	25.4	22.2	25.4	45.7 x 8TPI WHIT	22
BSMFFBM038AI	38.1	34.9	38.1	58.4 x 8TPI WHIT	22
BSMFFBM051AI	50.8	47.6	50.8	72.7 x 6TPI WHIT	22
BSMFFBM063AI	63.5	60.3	63.5	85.4 x 6TPI WHIT	22
BSMFFBM076AI	76.2	73.0	76.2	98.1 x 6TPI WHIT	22
BSMFFBM102AI	101.6	98.4	101.6	123.5 x 6TPI WHIT	22
BSMFFBM152AI	152.4	149.2	152.4	174.3 x 6TPI WHIT	22

BSM FLAT-FACED SEAL (O-RING) EPDM

Part Number	Size	A	B
BSMFFOR025E	25.4	33.3	6.5
BSMFFOR038E	38.1	46.0	6.5
BSMFFOR051E	50.8	58.7	6.5
BSMFFOR063E	63.5	71.4	6.5
BSMFFOR076E	76.2	84.1	6.5
BSMFFOR102E	101.6	109.5	6.5
BSMFFOR152E	152.4	160.3	6.5

BSM Adaptors

CF8M = 316 STAINLESS STEEL
ALL DIMENSIONS ARE IN MILLIMETRES

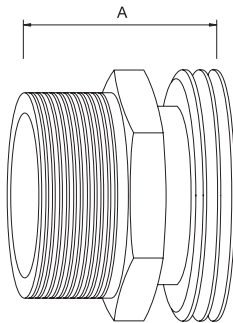

BSM MALE TO BSP MALE ADAPTOR CF8M

Part Number	Size	A
BSMMAA025X025EA	25.4	57
BSMMAA038X040EA	38.1	53
BSMMAA051X050EA	50.8	57
BSMMAA063X065EA	63.5	57
BSMMAA076X080EA	76.2	57
BSMMAA102X100EA	101.6	65
BSMMAA152X150EA	152.4	70

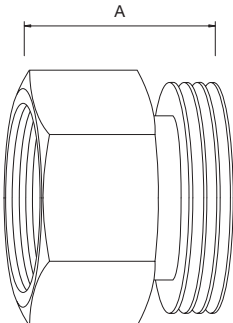

BSM MALE TO BSP FEMALE ADAPTOR CF8M

Part Number	Size	A
BSMMFA025X025EA	25.4	Note: 'A' dimension is available at time of order
BSMMFA038X040EA	38.1	
BSMMFA051X050EA	50.8	
BSMMFA063X065EA	63.5	
BSMMFA076X080EA	76.2	
BSMMFA102X100EA	101.6	
BSMMFA152X150EA	152.4	

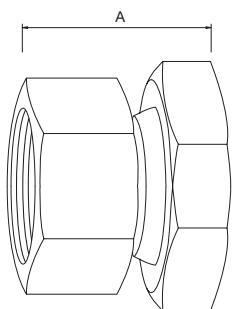

BSM FEMALE TO BSP FEMALE ADAPTOR CF8M

Part Number	Size	A
BSMFFA025X025A	25.4	Note: 'A' dimension is available at time of order
BSMFFA038X040A	38.1	
BSMFFA051X050A	50.8	
BSMFFA063X065A	63.5	
BSMFFA076X080A	76.2	
BSMFFA102X100A	101.6	
BSMFFA152X150A	152.4	

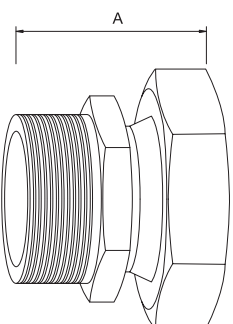

BSM FEMALE TO BSP MALE ADAPTOR CF8M

Part Number	Size	A
BSMFMA025X025EA	25.4	Note: 'A' dimension is available at time of order
BSMFMA038X040EA	38.1	
BSMFMA051X050EA	50.8	
BSMFMA063X065EA	63.5	
BSMFMA076X080EA	76.2	
BSMFMA102X100EA	101.6	
BSMFMA152X150EA	152.4	

BSM Spanners

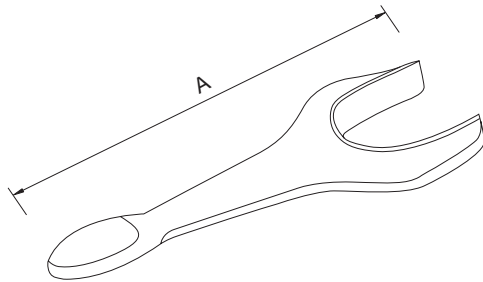

ALUMINIUM SPANNER

Part Number	Size	A
BSMAS025	25.4	250
BSMAS038	38.1	285
BSMAS051	50.8	310
BSMAS063	63.5	335
BSMAS076	76.2	365
BSMAS102	101.6	420
BSMAS152	152.4	475

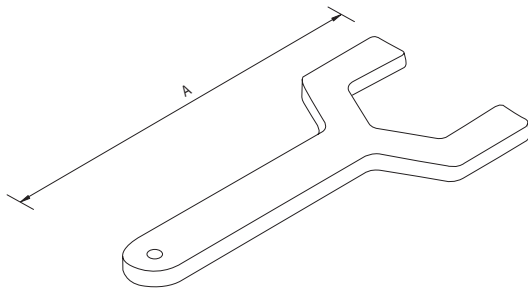

STAINLESS STEEL SPANNER

Part Number	Size	A
BSMSS025	25.4	250
BSMSS038	38.1	285
BSMSS051	50.8	310
BSMSS063	63.5	335
BSMSS076	76.2	365
BSMSS102	101.6	420
BSMSS152	152.4	475

BSM Hosetails

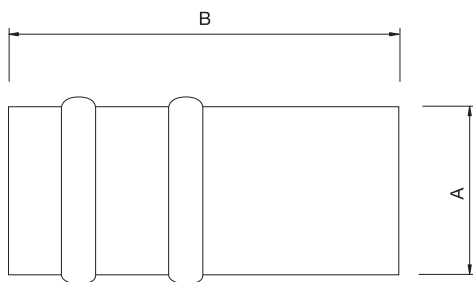

BSM DOUBLE HOSETAIL PLAIN 316

Part Number	Size	A	B
BSMDHT025A	25.4	25.4	110
BSMDHT032A	31.8	31.8	110
BSMDHT038A	38.1	38.1	120
BSMDHT051A	50.8	50.8	120
BSMDHT063A	63.5	63.5	135
BSMDHT076A	76.2	76.2	140
BSMDHT102A	101.6	101.6	145
BSMDHT152A	152.4	152.4	220

Tri-Fittings

CF8 = 304 STAINLESS STEEL, CF8M = 316 STAINLESS STEEL
ALL DIMENSIONS ARE IN MILLIMETRES



TRI-UNION COMPLETE SHORT

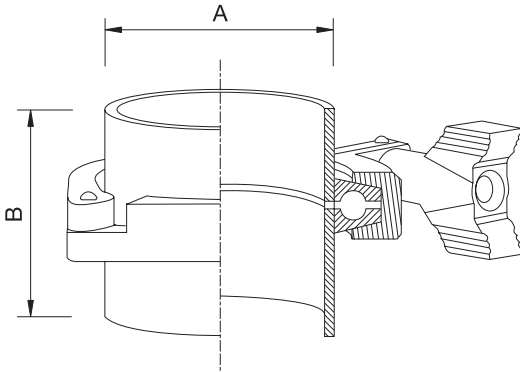

Part Number	Size	A	B
TRIBUSE013AI	12.7	12.7	27.3
TRIBUSE019AI	19.1	19.1	27.3
TRIBUSE025AI	25.4	25.4	27.3
TRIBUSE038AI	38.1	38.1	27.3
TRIBUSE051AI	50.8	50.8	27.3
TRIBUSE063AI	63.5	63.5	27.3
TRIBUSE076AI	76.2	76.2	27.3
TRIBUSE102AI	101.6	101.6	33.6
TRIBUSE152AI	152.4	152.4	45.0
TRIBUSE203AI	203.2	203.2	45.0

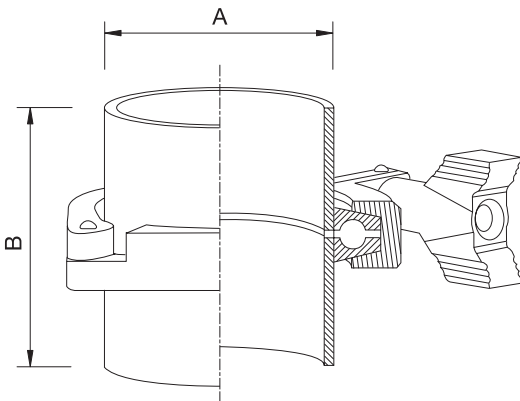

TRI-UNION COMPLETE LONG

Part Number	Size	A	B
TRIBULE013AI	12.7	12.7	59.3
TRIBULE019AI	19.1	19.1	59.3
TRIBULE025AI	25.4	25.4	59.3
TRIBULE038AI	38.1	38.1	59.3
TRIBULE051AI	50.8	50.8	59.3
TRIBULE063AI	63.5	63.5	59.3
TRIBULE076AI	76.2	76.2	59.3
TRIBULE102AI	101.6	101.6	59.3
TRIBULE152AI	152.4	152.4	59.3
TRIBULE203AI	203.2	203.2	59.3

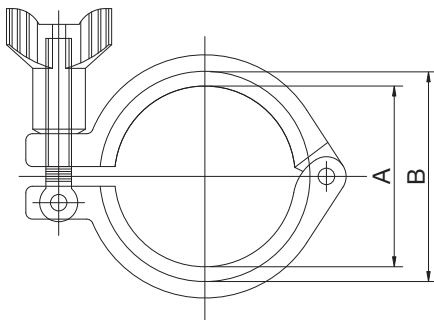

TRI-CLAMP CF8

Part Number	Size	A	B
TRICL013CI	12.7	27.8	37.0
TRICL019CI	19.1	27.8	37.0
TRICL025CI	25.4	44.4	53.6
TRICL038CI	38.1	44.4	53.6
TRICL051CI	50.8	57.8	67.0
TRICL063CI	63.5	71.4	80.6
TRICL076CI	76.2	84.0	94.2
TRICL102CI	101.6	110.0	122.2
TRICL152CI	152.4	155.4	170.4
TRICL203CI	203.2	205.0	220.0

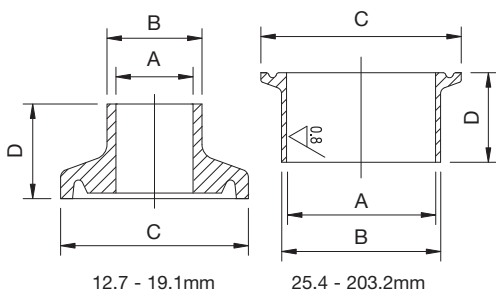

TRI-FERRULE SHORT CF8M

Part Number	Size	A	B	C	D
TRIFS013AI	12.7	9.5	12.7	25.2	12.7
TRIFS019AI	19.1	15.9	19.1	25.2	12.7
TRIFS025AI	25.4	22.2	25.4	50.5	12.7
TRIFS038AI	38.1	34.9	38.1	50.5	12.7
TRIFS051AI	50.8	47.6	50.8	64.0	12.7
TRIFS063AI	63.5	60.3	63.5	77.5	12.7
TRIFS076AI	76.2	73.0	76.2	91.0	12.7
TRIFS102AI	101.6	98.4	101.6	119.0	15.8
TRIFS152AI	152.4	149.2	152.4	166.8	21.5
TRIFS203AI	203.2	199.2	203.2	217.6	21.5

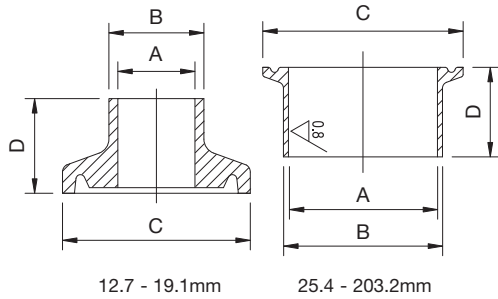

TRI-FERRULE LONG CF8M

Part Number	Size	A	B	C	D
TRIFL013AI	12.7	9.5	12.7	25.2	28.6
TRIFL019AI	19.1	15.9	19.1	25.2	28.6
TRIFL025AI	25.4	22.2	25.4	50.5	28.6
TRIFL038AI	38.1	34.9	38.1	50.5	28.6
TRIFL051AI	50.8	47.6	50.8	64.0	28.6
TRIFL063AI	63.5	60.3	63.5	77.5	28.6
TRIFL076AI	76.2	73.0	76.2	91.0	28.6
TRIFL102AI	101.6	98.4	101.6	119.0	28.6
TRIFL152AI	152.4	149.2	152.4	166.8	28.6
TRIFL203AI	203.2	199.2	203.2	217.6	28.6

TRI-SEAL (EPDM)

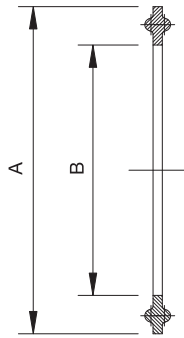

Part Number	Size	A	B
TRIS013EI	12.7	21.8	9.9
TRIS019EI	19.1	21.8	16.3
TRIS025EI	25.4	50.0	22.7
TRIS038EI	38.1	50.0	35.9
TRIS051EI	50.8	63.5	48.6
TRIS063EI	63.5	76.2	61.3
TRIS076EI	76.2	88.9	74.0
TRIS102EI	101.6	118.0	98.6
TRIS152EI	152.4	165.0	147.8
TRIS203EI	203.2	216.0	196.6

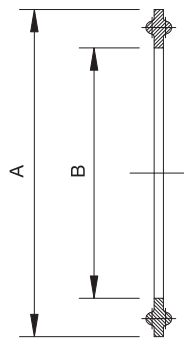

TRI-SEAL (TEFLON®)

Part Number	Size	A	B
TRIS013TI	12.7	21.8	9.9
TRIS019TI	19.1	21.8	16.3
TRIS025TI	25.4	50.0	22.7
TRIS038TI	38.1	50.0	35.9
TRIS051TI	50.8	63.5	48.6
TRIS063TI	63.5	76.2	61.3
TRIS076TI	76.2	88.9	74.0
TRIS102TI	101.6	118.0	98.6
TRIS152TI	152.4	165.0	147.8

TRI-CAP CF8M

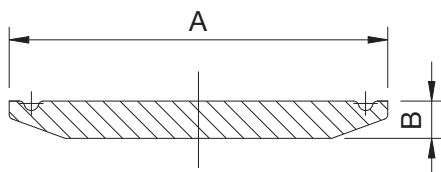

Part Number	Size	A	B
TRICAP013AI	12.7	25.2	5.0
TRICAP019AI	19.1	25.2	5.0
TRICAP025AI	25.4	50.5	6.3
TRICAP038AI	38.1	50.5	6.3
TRICAP051AI	50.8	64.0	6.3
TRICAP063AI	63.5	77.5	6.3
TRICAP076AI	76.2	91.0	6.3
TRICAP102AI	101.6	119.0	7.9
TRICAP152AI	152.4	166.7	11.1

Tube Fittings



Prochem offers a complete range of tube fittings in accordance with Australian Food Standard AS 1528.

45° BEND POLISHED 304 & 316

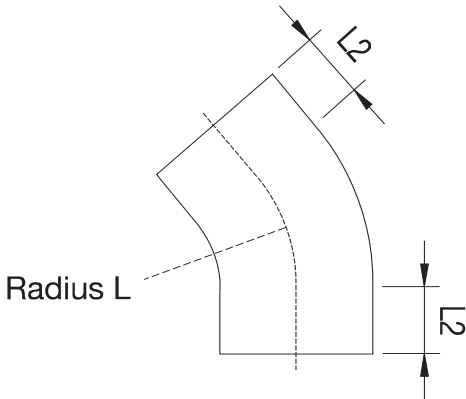

A INDICATES 316
C INDICATES 304

NOTE 1: "L2" REFERS TO THE STRAIGHT END EXTENSIONS

ALL DIMENSIONS ARE IN MILLIMETRES

Part Number	Size	L	L2	WT Nominal
TEL045D012.7AP	12.7	19.1	30.0	1.6
TEL045D012.7CP	12.7	19.1	30.0	1.6
TEL045D019.1AP	19.1	28.6	30.0	1.6
TEL045D019.1CP	19.1	28.6	30.0	1.6
TEL045D025.4AP	25.4	38.1	30.0	1.6
TEL045D025.4CP	25.4	38.1	30.0	1.6
TEL045D031.8AP	31.8	47.7	30.0	1.6
TEL045D031.8CP	31.8	47.7	30.0	1.6
TEL045D038.1AP	38.1	57.0	30.0	1.6
TEL045D038.1CP	38.1	57.0	30.0	1.6
TEL045D050.8AP	50.8	76.2	30.0	1.6
TEL045D050.8CP	50.8	76.2	30.0	1.6
TEL045D063.5AP	63.5	95.0	30.0	1.6
TEL045D063.5CP	63.5	95.0	30.0	1.6
TEL045D076.2AP	76.2	114.2	30.0	1.6
TEL045D076.2CP	76.2	114.2	30.0	1.6
TEL045D101.6AP	101.6	152.4	30.0	1.6
TEL045D101.6CP	101.6	152.4	30.0	1.6
TEL045D127.0AP	127.0	190.5	40.0	1.6
TEL045D127.0CP	127.0	190.5	40.0	1.6
TEL045E152.4AP	152.4	228.5	40.0	2.0
TEL045E152.4CP	152.4	228.5	40.0	2.0

90° BEND POLISHED 304 & 316

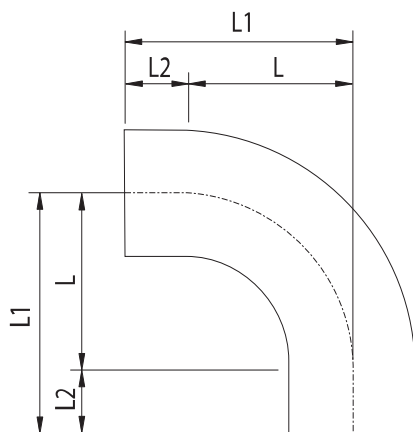

A INDICATES 316
C INDICATES 304

NOTE 1: PROCHEM STANDARD 90° BEND STOCK IS "L1" DIMENSION CONFIGURATION

NOTE 2: "L2" REFERS TO THE STRAIGHT END EXTENSIONS

ALL DIMENSIONS ARE IN MILLIMETRES

Part Number	Size	L	L1	L2	WT Nominal
TEL090D012.7AP	12.7	19.1	49.1	30.0	1.6
TEL090D012.7CP	12.7	19.1	49.1	30.0	1.6
TEL090D019.1AP	19.1	28.6	58.6	30.0	1.6
TEL090D019.1CP	19.1	28.6	58.6	30.0	1.6
TEL090D025.4AP	25.4	38.1	68.1	30.0	1.6
TEL090D025.4CP	25.4	38.1	68.1	30.0	1.6
TEL090D031.8AP	31.8	47.7	77.7	30.0	1.6
TEL090D031.8CP	31.8	47.7	77.7	30.0	1.6
TEL090D038.1AP	38.1	57.0	87.0	30.0	1.6
TEL090D038.1CP	38.1	57.0	87.0	30.0	1.6
TEL090D050.8AP	50.8	76.2	106.2	30.0	1.6
TEL090D050.8CP	50.8	76.2	106.2	30.0	1.6
TEL090D063.5AP	63.5	95.0	125.0	30.0	1.6
TEL090D063.5CP	63.5	95.0	125.0	30.0	1.6
TEL090D076.2AP	76.2	114.2	144.2	30.0	1.6
TEL090D076.2CP	76.2	114.2	144.2	30.0	1.6
TEL090D101.6AP	101.6	152.4	182.4	30.0	1.6
TEL090D101.6CP	101.6	152.4	182.4	30.0	1.6
TEL090D127.0AP	127.0	190.5	230.5	40.0	1.6
TEL090D127.0CP	127.0	190.5	230.5	40.0	1.6
TEL090E152.4AP	152.4	228.5	268.5	40.0	2.0
TEL090E152.4CP	152.4	228.5	268.5	40.0	2.0

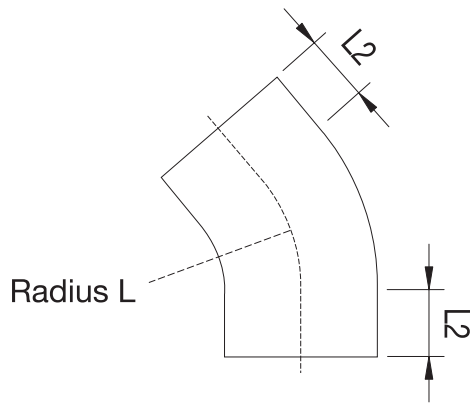

A INDICATES 316
B INDICATED 316L
C INDICATES 304
D INDICATES 304L

NOTE 1: "L2" REFERS TO THE STRAIGHT END EXTENSIONS

ALL DIMENSIONS ARE IN MILLIMETRES



* Elbows are manufactured to EN 10253-3 or EN 10253-4. If EN 10253-4 is required, please check with your local Prochem office for availability of stock.

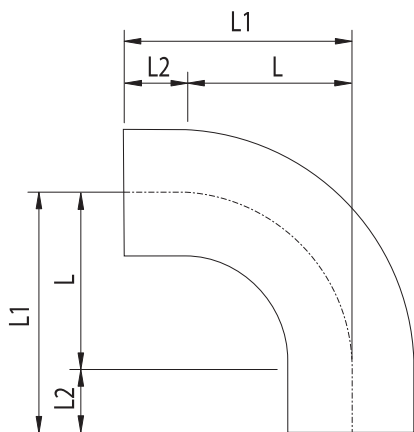

A INDICATES 316
C INDICATES 304

NOTE 1: PROCHEM STANDARD 90° BEND STOCK IS "L1" DIMENSION CONFIGURATION

NOTE 2: "L2" REFERS TO THE STRAIGHT END EXTENSIONS

ALL DIMENSIONS ARE IN MILLIMETRES

45° BEND UNPOLISHED 304 & 316

Part Number	Size	L	L2	WT Nominal
TEL045D012.7A	12.7	19.1	30.0	1.6
TEL045D012.7C	12.7	19.1	30.0	1.6
TEL045D019.1A	19.1	28.6	30.0	1.6
TEL045D019.1C	19.1	28.6	30.0	1.6
TEL045D025.4A	25.4	38.1	30.0	1.6
TEL045D025.4C	25.4	38.1	30.0	1.6
TEL045D031.8A	31.8	47.7	30.0	1.6
TEL045D031.8C	31.8	47.7	30.0	1.6
TEL045D038.1A	38.1	57.0	30.0	1.6
TEL045D038.1C	38.1	57.0	30.0	1.6
TEL045D050.8A	50.8	76.2	30.0	1.6
TEL045D050.8C	50.8	76.2	30.0	1.6
TEL045D063.5A	63.5	95.0	30.0	1.6
TEL045D063.5C	63.5	95.0	30.0	1.6
TEL045D076.2A	76.2	114.2	30.0	1.6
TEL045D076.2C	76.2	114.2	30.0	1.6
TEL045D101.6A	101.6	152.4	30.0	1.6
TEL045D101.6C	101.6	152.4	30.0	1.6
TEL045D127.0A	127.0	190.5	40.0	1.6
TEL045D127.0C	127.0	190.5	40.0	1.6
TEL045E152.4A	152.4	228.5	40.0	2.0
TEL045E152.4C	152.4	228.5	40.0	2.0
TEL045E204.0B*	204.0	300.0	-	2.0
TEL045E204.0D*	204.0	300.0	-	2.0
TEL045E254.0B*	254.0	375.0	-	2.0
TEL045E254.0D*	254.0	375.0	-	2.0
TEL045F304.8B*	304.8	450.0	-	2.5
TEL045F304.8D*	304.8	450.0	-	2.5

90° BEND UNPOLISHED 304 & 316

Part Number	Size	L	L1	L2	WT Nominal
TEL090D012.7A	12.7	19.1	49.1	30.0	1.6
TEL090D012.7C	12.7	19.1	49.1	30.0	1.6
TEL090D019.1A	19.1	28.6	58.6	30.0	1.6
TEL090D019.1C	19.1	28.6	58.6	30.0	1.6
TEL090D025.4A	25.4	38.1	68.1	30.0	1.6
TEL090D025.4C	25.4	38.1	68.1	30.0	1.6
TEL090D031.8A	31.8	47.7	77.7	30.0	1.6
TEL090D031.8C	31.8	47.7	77.7	30.0	1.6
TEL090D038.1A	38.1	57.0	87.0	30.0	1.6
TEL090D038.1C	38.1	57.0	87.0	30.0	1.6
TEL090D050.8A	50.8	76.2	106.2	30.0	1.6
TEL090D050.8C	50.8	76.2	106.2	30.0	1.6
TEL090D063.5A	63.5	95.0	125.0	30.0	1.6
TEL090D063.5C	63.5	95.0	125.0	30.0	1.6
TEL090D076.2A	76.2	114.2	144.2	30.0	1.6
TEL090D076.2C	76.2	114.2	144.2	30.0	1.6
TEL090D101.6A	101.6	152.4	182.4	30.0	1.6
TEL090D101.6C	101.6	152.4	182.4	30.0	1.6
TEL090D127.0A	127.0	190.5	230.5	40.0	1.6
TEL090D127.0C	127.0	190.5	230.5	40.0	1.6
TEL090E152.4A	152.4	228.5	268.5	40.0	2.0
TEL090E152.4C	152.4	228.5	268.5	40.0	2.0
TEL090E204.0B*	204.0	300.0	300.0	-	2.0
TEL090E204.0D*	204.0	300.0	300.0	-	2.0
TEL090E254.0B*	254.0	375.0	375.0	-	2.0
TEL090E254.0D*	254.0	375.0	375.0	-	2.0
TEL090F304.8B*	304.8	450.0	450.0	-	2.5
TEL090F304.8D*	304.8	450.0	450.0	-	2.5
TEL090H355.6B*	355.6	525.0	525.0	-	3.0



180° BEND POLISHED 304 & 316

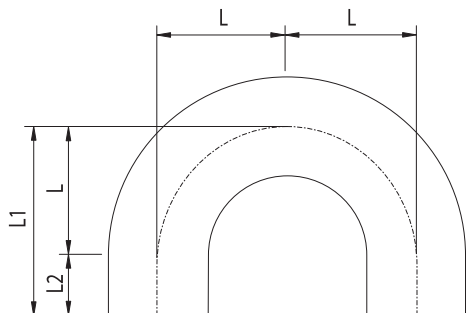

Centre measurement subject to change due to differing feed tube tempers

A INDICATES 316
C INDICATES 304

NOTE 1: “L2” REFERS TO THE STRAIGHT END EXTENSIONS
ALL DIMENSIONS ARE IN MILLIMETRES

Part Number	Size	L	L1	L2	WT Nominal
TEL180D012.7AP	12.7	19.1	49.1	30.0	1.6
TEL180D012.7CP	12.7	19.1	49.1	30.0	1.6
TEL180D019.1AP	19.1	28.6	58.6	30.0	1.6
TEL180D019.1CP	19.1	28.6	58.6	30.0	1.6
TEL180D025.4AP	25.4	38.1	68.1	30.0	1.6
TEL180D025.4CP	25.4	38.1	68.1	30.0	1.6
TEL180D031.8AP	31.8	47.7	77.7	30.0	1.6
TEL180D031.8CP	31.8	47.7	77.7	30.0	1.6
TEL180D038.1AP	38.1	57.0	87.0	30.0	1.6
TEL180D038.1CP	38.1	57.0	87.0	30.0	1.6
TEL180D050.8AP	50.8	76.2	106.2	30.0	1.6
TEL180D050.8CP	50.8	76.2	106.2	30.0	1.6
TEL180D063.5AP	63.5	95.0	125.0	30.0	1.6
TEL180D063.5CP	63.5	95.0	125.0	30.0	1.6
TEL180D076.2AP	76.2	114.2	144.2	30.0	1.6
TEL180D076.2CP	76.2	114.2	144.2	30.0	1.6
TEL180D101.6AP	101.6	152.4	182.4	30.0	1.6
TEL180D101.6CP	101.6	152.4	182.4	30.0	1.6

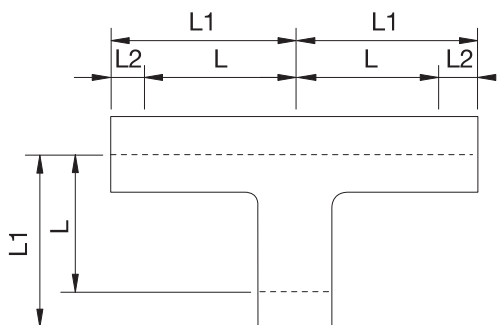

A INDICATES 316
C INDICATES 304

NOTE 1: PROCHEM STANDARD EQUAL TEE STOCK IS “L” DIMENSION CONFIGURATION

NOTE 2: “L2” REFERS TO THE STRAIGHT END EXTENSIONS

ALL DIMENSIONS ARE IN MILLIMETRES

EQUAL TEE POLISHED 304 & 316

Part Number	Size	L	L1	L2	WT Nominal
TETD012.7AP	12.7	19.1	49.1	30.0	1.6
TETD012.7CP	12.7	19.1	49.1	30.0	1.6
TETD019.1AP	19.1	28.6	58.6	30.0	1.6
TETD019.1CP	19.1	28.6	58.6	30.0	1.6
TETD025.4AP	25.4	38.1	68.1	30.0	1.6
TETD025.4CP	25.4	38.1	68.1	30.0	1.6
TETD031.8AP	31.8	47.7	77.7	30.0	1.6
TETD031.8CP	31.8	47.7	77.7	30.0	1.6
TETD038.1AP	38.1	57.0	87.0	30.0	1.6
TETD038.1CP	38.1	57.0	87.0	30.0	1.6
TETD050.8AP	50.8	76.2	106.2	30.0	1.6
TETD050.8CP	50.8	76.2	106.2	30.0	1.6
TETD063.5AP	63.5	95.0	125.0	30.0	1.6
TETD063.5CP	63.5	95.0	125.0	30.0	1.6
TETD076.2AP	76.2	114.2	144.2	30.0	1.6
TETD076.2CP	76.2	114.2	144.2	30.0	1.6
TETD101.6AP	101.6	152.4	182.4	30.0	1.6
TETD101.6CP	101.6	152.4	182.4	30.0	1.6
TETD127.0AP	127.0	190.5	230.5	40.0	1.6
TETD127.0CP	127.0	190.5	230.5	40.0	1.6
TETD152.4AP	152.4	228.5	268.5	40.0	1.6
TETD152.4CP	152.4	228.5	268.5	40.0	1.6



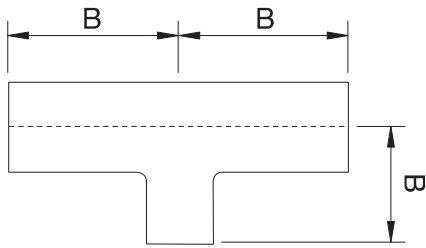

A INDICATES 316
ALL DIMENSIONS ARE IN MILLIMETRES

REDUCING TEE POLISHED 316

Part Number	Run Size	B	WT Nominal
TRTD019.1 x _ _ _ . _ A	19.1	B = 1.5 branch diameter or 80mm minimum	1.6
TRTD025.4 x _ _ _ . _ A	25.4		1.6
TRTD031.8 x _ _ _ . _ A	31.8		1.6
TRTD038.1 x _ _ _ . _ A	38.1		1.6
TRTD050.8 x _ _ _ . _ A	50.8		1.6
TRTD063.5 x _ _ _ . _ A	63.5		1.6
TRTD076.2 x _ _ _ . _ A	76.2		1.6
TRTD101.6 x _ _ _ . _ A	101.6		1.6
TRTD127.0 x _ _ _ . _ A	127.0		1.6
TRTD152.4 x _ _ _ . _ A	152.4		1.6

Note: Insert reduction size to complete part number

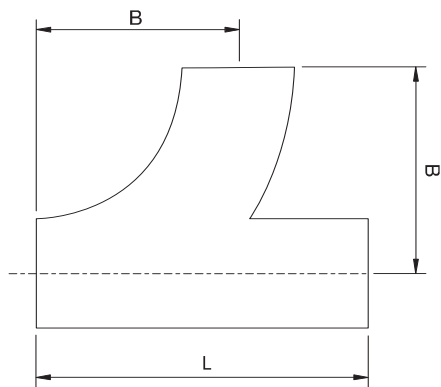

A INDICATES 316
ALL DIMENSIONS ARE IN MILLIMETRES

SWEEP TEE* POLISHED 316

Part Number	Size	B	L	WT Nominal
TSTD025.4A	25.4	51	90	1.6
TSTD031.8A	31.8	60	105	1.6
TSTD038.1A	38.1	70	120	1.6
TSTD050.8A	50.8	88	150	1.6
TSTD063.5A	63.5	122	210	1.6
TSTD076.2A	76.2	140	240	1.6
TSTD101.6A	101.6	179	310	1.6
TSTD127.0A	127.0	230	400	1.6
TSTE152.4A	152.4	270	460	2.0

**Double sweep tees available on request*

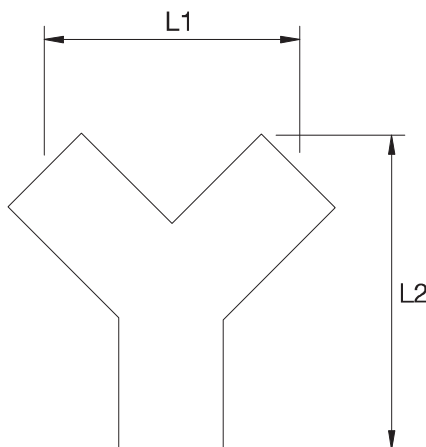

A INDICATES 316
ALL DIMENSIONS ARE IN MILLIMETRES

Y-PIECE POLISHED 316

Part Number	Size	L1	L2	WT Nominal
TYPD025.4A	25.4	88	72	1.6
TYPD031.8A	31.8	110	90	1.6
TYPD038.1A	38.1	132	108	1.6
TYPD050.8A	50.8	176	143	1.6
TYPD063.5A	63.5	220	179	1.6
TYPD076.2A	76.2	364	215	1.6
TYPD101.6A	101.6	352	287	1.6
TYPD127.0A	127.0	359	440	1.6
TYPD152.4A	152.4	430	529	1.6

CONCENTRIC REDUCER POLISHED 316

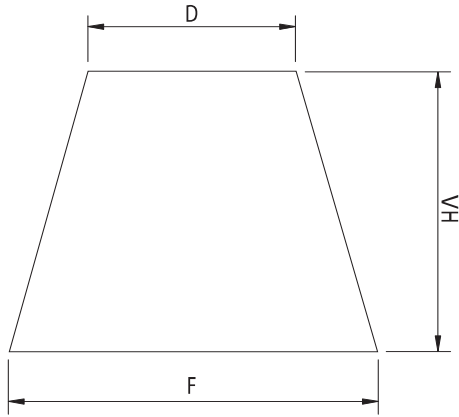

A INDICATES 316
ALL DIMENSIONS ARE IN MILLIMETRES

Part Number	Size	F	D	WT Nominal
TCR019.1X012.7DA	19.1X12.7	19.1	12.7	1.6
TCR025.4X012.7DA	25.4X12.7	25.4	12.7	1.6
TCR025.4X019.1DA	25.4X19.1	25.4	19.1	1.6
TCR031.8X019.1DA	31.8X19.1	31.8	19.1	1.6
TCR031.8X025.4DA	31.8X25.4	31.8	25.4	1.6
TCR038.1X019.1DA	38.1X19.1	38.1	19.1	1.6
TCR038.1X025.4DA	38.1X25.4	38.1	25.4	1.6
TCR038.1X031.8DA	38.1X31.8	38.1	31.8	1.6
TCR050.8X019.1DA	50.8X19.1	50.8	19.1	1.6
TCR050.8X025.4DA	50.8X25.4	50.8	25.4	1.6
TCR050.8X031.8DA	50.8X31.8	50.8	31.8	1.6
TCR050.8X038.1DA	50.8X38.1	50.8	38.1	1.6
TCR063.5X025.4DA	63.5X25.4	63.5	25.4	1.6
TCR063.5X031.8DA	63.5X31.8	63.5	31.8	1.6
TCR063.5X038.1DA	63.5X38.1	63.5	38.1	1.6
TCR063.5X050.8DA	63.5X50.8	63.5	50.8	1.6
TCR076.2X025.4DA	76.2X25.4	76.2	25.4	1.6
TCR076.2X038.1DA	76.2x38.1	76.2	38.1	1.6
TCR076.2X050.8DA	76.2X50.8	76.2	50.8	1.6
TCR076.2X063.5DA	76.2X63.5	76.2	63.5	1.6
TCR101.6X025.4DA	101.6X25.4	101.6	25.4	1.6
TCR101.6X038.1DA	101.6X38.1	101.6	38.1	1.6
TCR101.6X050.8DA	101.6X50.8	101.6	50.8	1.6
TCR101.6X063.5DA	101.6X63.5	101.6	63.5	1.6
TCR101.6X076.2DA	101.6X76.2	101.6	76.2	1.6
TCR127.0X050.8DA	127.0X50.8	127.0	50.8	1.6
TCR127.0X063.5DA	127.0X63.5	127.0	63.5	1.6
TCR127.0X076.2DA	127.0X76.2	127.0	76.2	1.6
TCR127.0X101.6DA	127.0X101.6	127.0	101.6	1.6
TCR152.4X050.8DA	152.4X50.8	152.4	50.8	1.6
TCR152.4X063.5DA	152.4X63.5	152.4	63.5	1.6
TCR152.4X076.2DA	152.4X76.2	152.4	76.2	1.6
TCR152.4X101.6DA	152.4X101.6	152.4	101.6	1.6
TCR152.4X127.0DA	152.4X127.0	152.4	127.0	1.6

LEGEND

- D = Smaller Diameter of Reducer
- F = Larger Diameter of Reducer
- VH = Height of Reducer
- IN MOST CASES VH = F

Full Flow Tube Reducer VH = 4 (F-D)

Standard Tube Reducer VH = F



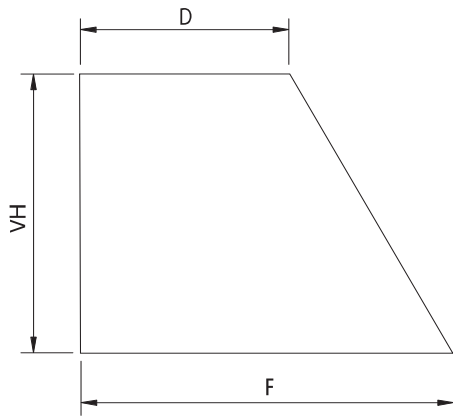

A INDICATES 316

ALL DIMENSIONS ARE IN MILLIMETRES

LEGEND

D = Smaller Diameter of Reducer

F = Larger Diameter of Reducer

VH = Height of Reducer

IN MOST CASES VH = F

Full Flow Tube Reducer VH = 4 (F-D)

Standard Tube Reducer VH = F

ECCENTRIC REDUCER POLISHED 316

Part Number	Size	F	D	WT Nominal
TER019.1X012.7DA	19.1X12.7	19.1	12.7	1.6
TER025.4X012.7DA	25.4X12.7	25.4	12.7	1.6
TER025.4X019.1DA	25.4X19.1	25.4	19.1	1.6
TER031.8X019.1DA	31.8X19.1	31.8	19.1	1.6
TER031.8X025.4DA	31.8X25.4	31.8	25.4	1.6
TER038.1X019.1DA	38.1X19.1	38.1	19.1	1.6
TER038.1X025.4DA	38.1X25.4	38.1	25.4	1.6
TER038.1X031.8DA	38.1X31.8	38.1	31.8	1.6
TER050.8X019.1DA	50.8X19.1	50.8	19.1	1.6
TER050.8X025.4DA	50.8X25.4	50.8	25.4	1.6
TER050.8X031.8DA	50.8X31.8	50.8	31.8	1.6
TER050.8X038.1DA	50.8X38.1	50.8	38.1	1.6
TER063.5X025.4DA	63.5X25.4	63.5	25.4	1.6
TER063.5X031.8DA	63.5X31.8	63.5	31.8	1.6
TER063.5X038.1DA	63.5X38.1	63.5	38.1	1.6
TER063.5X050.8DA	63.5X50.8	63.5	50.8	1.6
TER076.2X025.4DA	76.2X25.4	76.2	25.4	1.6
TER076.2X038.1DA	76.2X38.1	76.2	38.1	1.6
TER076.2X050.8DA	76.2X50.8	76.2	50.8	1.6
TER076.2X063.5DA	76.2X63.5	76.2	63.5	1.6
TER101.6X025.4DA	101.6X25.4	101.6	25.4	1.6
TER101.6X038.1DA	101.6X38.1	101.6	38.1	1.6
TER101.6X050.8DA	101.6X50.8	101.6	50.8	1.6
TER101.6X063.5DA	101.6X63.5	101.6	63.5	1.6
TER101.6X076.2DA	101.6X76.2	101.6	76.2	1.6
TER127.0X050.8DA	127.0X50.8	127.0	50.8	1.6
TER127.0X063.5DA	127.0X63.5	127.0	63.5	1.6
TER127.0X076.2DA	127.0X76.2	127.0	76.2	1.6
TER127.0X101.6DA	127.0X101.6	127.0	101.6	1.6
TER152.4X050.8DA	152.4X050.8	152.4	50.8	1.6
TER152.4X063.5DA	152.4X063.5	152.4	63.5	1.6
TER152.4X076.2DA	152.4X076.2	152.4	76.2	1.6
TER152.4X101.6DA	152.4X101.6	152.4	101.6	1.6
TER152.4X127.0DA	152.4X127.0	152.4	127.0	1.6

DISHED CAPS POLISHED 316

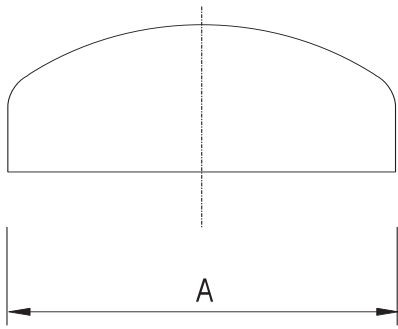

Part Number	Size	A	WT Nominal
TCAPD025.4DA	25.4	25.4	1.6
TCAPD031.8DA	31.8	31.8	1.6
TCAPD038.1DA	38.1	38.1	1.6
TCAPD050.8DA	50.8	50.8	1.6
TCAPD063.5DA	63.5	63.5	1.6
TCAPD076.2DA	76.2	76.2	1.6
TCAPD101.6DA	101.6	101.6	1.6
TCAPD127.0DA	127.0	127.0	1.6
TCAPD152.4DA	152.4	152.4	1.6

ALL DIMENSIONS ARE IN MILLIMETRES

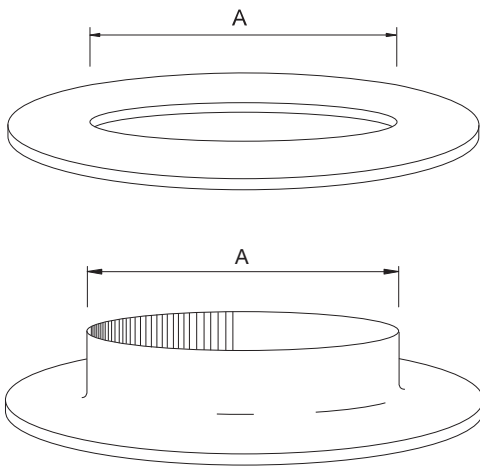

FACE/ANGLE RINGS 316

Part Number	Size	A	WT Nominal
TFR025.4A	25.4	25.4	1.6
TFR031.8A	31.8	31.8	1.6
TFR038.1A	38.1	38.1	1.6
TFR050.8A	50.8	50.8	1.6
TAR063.5A	63.5	63.5	1.6
TAR076.2A	76.2	76.2	1.6
TAR101.6A	101.6	101.6	1.6
TAR127.0A	127.0	127.0	1.6
TAR152.4A	152.4	152.4	1.6

Note: Face ring up to 50.8 mm and angle ring for sizes 63.5 mm and above

ALL DIMENSIONS ARE IN MILLIMETRES

TAPER NIPPLES

Prochem manufactured BSP taper nipples are machined from heavy wall pipe allowing the ID of the fitting to be machined to suit OD sizes allowing the tube to be fully inserted.



Part Number	Thread Size	Suit Tube OD
BSPATN006A	R6 (1/8")	3.2 mm (1/8")
BSPATN008A	R8 (1/4")	6.35 mm (1/4")
BSPATN010A	R10 (3/8")	9.53 mm (3/8")
BSPATN015A	R15 (1/2")	12.7 mm (1/2")
BSPATN020A	R20 (3/4")	19.05 mm (3/4")
BSPATN025A	R25 (1")	25.4 mm (1")
BSPATN032A	R32 (1-1/4")	31.8 mm (1-1/4")
BSPATN040A	R40 (1-1/2")	38.1 mm (1-1/2")
BSPATN050A	R50 (2")	50.8 mm (2")
BSPATN065A	R65 (2-1/2")	63.5 mm (2-1/2")
BSPATN080A	R80 (3")	70.2 mm (3")
BSPATN100A	R100 (4")	101.6 mm (4")

Clamps and Hangers

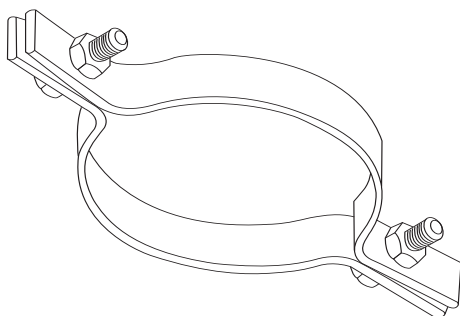
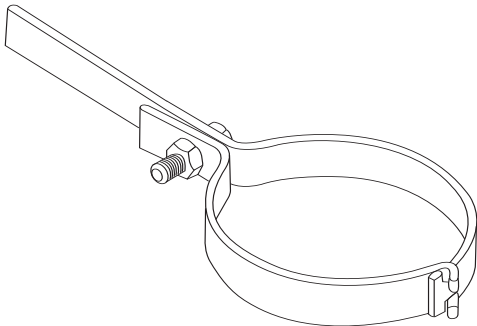
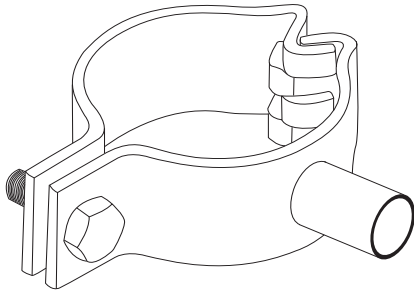
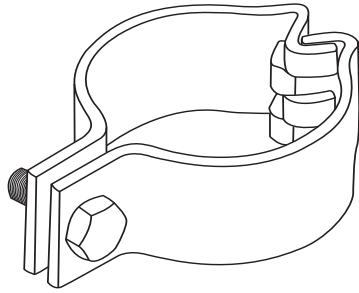

ALL DIMENSIONS ARE IN MILLIMETRES

PLAIN CLAMPS (INTERLOCKING) 304

Part Number	Size
TCIHCP013C	12.7
TCIHCP019C	19.1
TCIHCP025C	25.4
TCIHCP032C	31.8
TCIHCP038C	38.1
TCIHCP051C	50.8
TCIHCP063C	63.5
TCIHCP076C	76.2
TCIHCP102C	101.6
TCIHCP127C	127.0
TCIHCP152C	152.4

BOSSED CLAMPS 304

Part Number	Size
TCIHCB013C	12.7
TCIHCB019C	19.1
TCIHCB025C	25.4
TCIHCB032C	31.8
TCIHCB038C	38.1
TCIHCB051C	50.8
TCIHCB063C	63.5
TCIHCB076C	76.2
TCIHCB102C	101.6
TCIHCB127C	127.0
TCIHCB152C	152.4

TANG CLAMPS 304

Part Number	Size
TCITST013C	12.7
TCITST019C	19.1
TCITST025C	25.4
TCITST032C	31.8
TCITST038C	38.1
TCITST051C	50.8
TCITST063C	63.5
TCITST076C	76.2
TCITST102C	101.6
TCITST127C	127.0
TCITST152C	152.4

DOUBLE BOLTED CLAMPS 304

Part Number	Size
TCDBCP013C	12.7
TCDBCP019C	19.1
TCDBCP025C	25.4
TCDBCP032C	31.8
TCDBCP038C	38.1
TCDBCP051C	50.8
TCDBCP063C	63.5
TCDBCP076C	76.2
TCDBCP102C	101.6
TCDBCP127C	127.0
TCDBCP152C	152.4

Non Return Valves

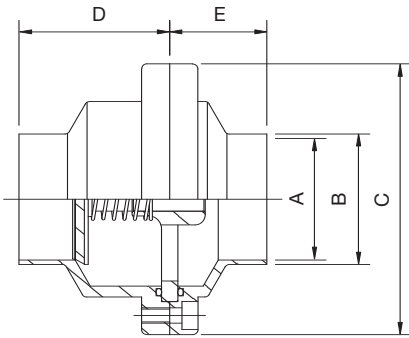

FLANGE WELD END 316

Part Number	Size	A	B	C	D	E
VNRF025.4WEA	25.4	22.2	25.4	80	59	38
VNRF038.1WEA	38.1	34.9	38.1	93	59	38
VNRF050.8WEA	50.8	47.6	50.8	106	59	38
VNRF063.5WEA	63.5	60.3	63.5	123	59	38
VNRF076.2WEA	76.2	73.0	76.2	136	59	44

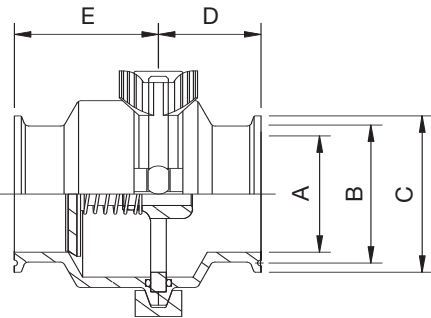

CLAMP CLAMP END 316

Part Number	Size	A	B	C	D	E
VNRC025.4TEA	25.4	22.2	43.5	50.5	42	59
VNRC038.1TEA	38.1	34.9	43.5	50.5	42	59
VNRC050.8TEA	50.8	47.6	56.5	64.0	42	59
VNRC063.5TEA	63.5	60.3	70.5	77.5	42	59
VNRC076.2TEA	76.2	73.0	83.5	91.0	42	59

Maximum Working Pressure 10 bar

ALL DIMENSIONS ARE IN MILLIMETRES

Size	Cracking Pressure kPa (psi)
25.4 mm (1")	20 (3)
38.1 mm (1-1/2")	11 (1.6)
50.8 mm (2")	4.1 (0.6)
63.4 mm (2-1/2")	9 (1.3)
76.2 mm (3")	5.5 (0.8)
101.6 mm (4")	6.2 (0.9)



Butterfly Valves

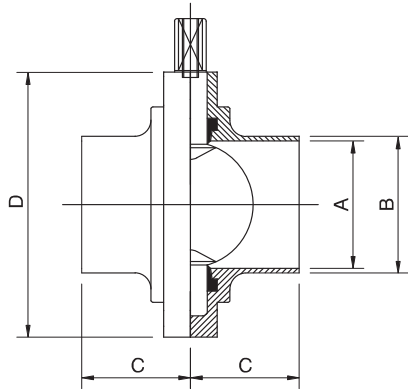

WELD/WELD BUTTERFLY VALVE 316 C/W NYLON HANDLE

Part Number	Size	A	B	C	D
VBF025.4WEA	25.4	22.1	25.4	34	79
VBF038.1WEA	38.1	34.8	38.1	38	85
VBF050.8WEA	50.8	47.5	50.8	40	105
VBF063.5WEA	63.5	60.2	63.5	40	112
VBF076.2WEA	76.2	72.2	76.2	41	125
VBF101.6WEA	101.6	97.6	101.6	44	157

Note: All valves come standard with EPDM seat

WELD/WELD BUTTERFLY VALVE 316 C/W STAINLESS STEEL LOCKABLE HANDLE

Part Number	Size	A	B	C	D
VBF025.4WEAL	25.4	22.1	25.4	34	79
VBF038.1WEAL	38.1	34.8	38.1	38	85
VBF050.8WEAL	50.8	47.5	50.8	40	105
VBF063.5WEAL	63.5	60.2	63.5	40	112
VBF076.2WEAL	76.2	72.2	76.2	41	125
VBF101.6WEAL	101.6	97.6	101.6	44	157

Note: All valves come standard with EPDM seat

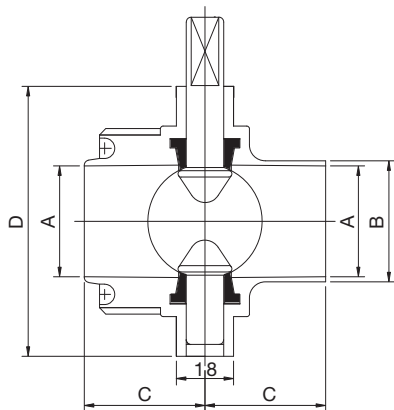

BSM MALE/WELD BUTTERFLY VALVE 316 C/W STAINLESS STEEL LOCKABLE HANDLE

Part Number	Size	A	B	C	D
VBF025.4BMWEALA	25.4	22.1	25.4	34	79
VBF038.1BMWEALA	38.1	34.8	38.1	38	85
VBF050.8BMWEALA	50.8	47.5	50.8	40	105
VBF076.2BMWEALA	76.2	72.2	76.2	41	125
VBF101.6BMWEALA	101.6	97.6	101.6	50/44	157

Note: All valves come standard with EPDM seat

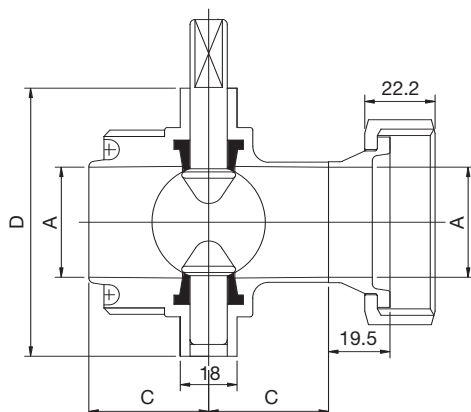

BSM MALE/FEMALE BUTTERFLY VALVE 316 C/W STAINLESS STEEL LOCKABLE HANDLE

Part Number	Size	A	B	C	D
VBF025.4BMFEALA	25.4	22.1	34	79	79
VBF038.1BMFEALA	38.1	34.8	38	85	85
VBF050.8BMFEALA	50.8	47.5	40	105	105
VBF076.2BMFEALA	76.2	72.2	41	125	112
VBF101.6BMFEALA	101.6	97.6	50/44	157	125

Note: All valves come standard with EPDM seat



Prochem’s hygienic butterfly valves come complete with 12 position lock-in plate to allow fine adjustment of flow.

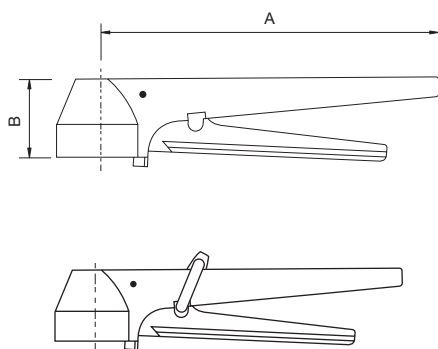

ALL DIMENSIONS ARE IN MILLIMETRES

LOCKABLE STAINLESS STEEL HANDLE OPTION

Part Number	Size	A	B
VBFHANDLEA	25.4 - 101.6	167	38

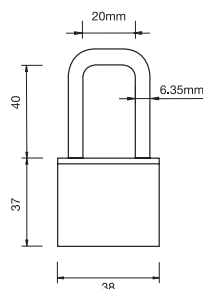

PADLOCK DETAILS

Dimensions for suitable padlocks are provided. Padlock can be mounted on lockable multi position handle as shown.

TECHNICAL DATA

WARNING: Improper selection or use of products described herein can cause personal injury or property damage. Whilst every care has been taken in preparation of the data contained in this handbook, Prochem accepts no liability for the accuracy of information supplied. It is solely the responsibility of the system designer and user to select products suitable for their specific application requirements and to ensure proper installation, operation, and maintenance of these products. Material compatibility, product ratings, and application details should be considered in the selection.

BUTTERFLY VALVE TORQUE FOR FULL OPEN/CLOSE

SIZE	TORQUE
25.4	<9.80 N/m
38.1	<9.80 N/m
50.8	12.74 N/m
63.5	14.70 N/m
76.2	19.60 N/m
101.6	30.30 N/m

WORKING PRESSURES

Minus 0.9 bar to 10 bar maximum, ambient temperature water. Standard range of Prochem Butterfly Valves are supplied with EPDM seat.

Precision Actuators

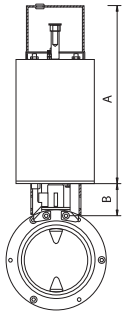
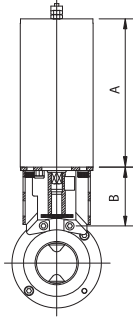
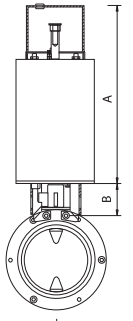
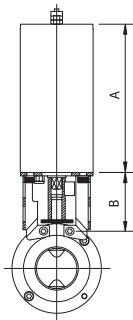

DOUBLE ACTING PNEUMATIC 25-76 mm SIZE RANGE

Part Number	Size	A	B
VPABF076DA	25-76 mm	174	69

DOUBLE ACTING PNEUMATIC 101.6 mm SIZE

Part Number	Size	A	B
VPABF102DA	101.6 mm	272	89

SPRING RETURN PNEUMATIC 25-76 mm SIZE RANGE

Part Number	Size	A	B
VPABF076SR	25-76 mm	174	69

SPRING RETURN PNEUMATIC 101.6 mm SIZE

Part Number	Size	A	B
VPABF102SR	101.6 mm	272	89

PROCHEM K1 ACTUATOR DATA VALVE SIZE RANGE 25-76 mm

for both double acting and spring return

BODY MATERIAL	304 Stainless Steel
OUTPUT TORQUE	Max. 20 N/m
SHUT OFF TIME	1.5 seconds
WEIGHT	3.85 kg
OPERATING AIR PRESSURE	4 m/kg; min. 5 bar; max. 9 bar compressed air
AIR CONSUMPTION	0.266 litre at 5 bar

PROCHEM K4 ACTUATOR DATA VALVE SIZE 101.6 mm

for both double acting and spring return

BODY MATERIAL	304 Stainless Steel
OUTPUT TORQUE	Max. 30 N/m
SHUT OFF TIME	1.7 seconds
WEIGHT	4.7 kg
OPERATING AIR PRESSURE	4 m/kg; min. 5 bar; max. 9 bar compressed air
AIR CONSUMPTION	0.550 litre at 5 bar

Sight Glass

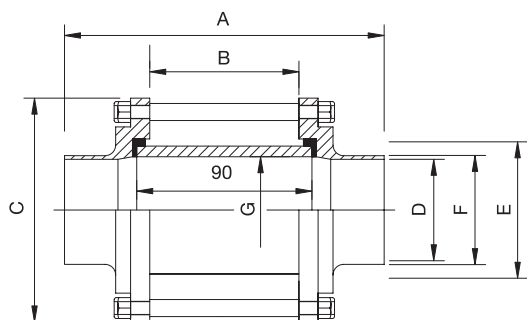
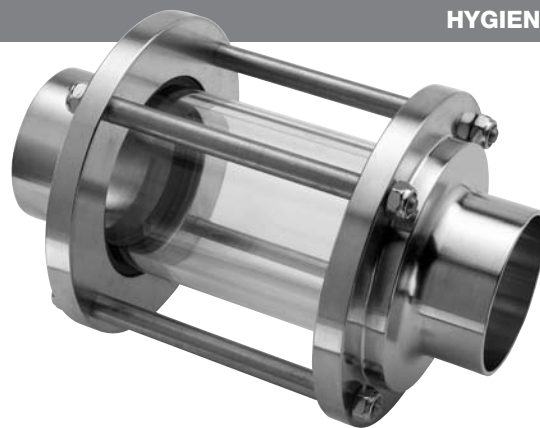

SIGHT GLASS (LANTERN) WELD END 316

Part Number	Size	A	B	C	D	E	F	G
BSMSGLO25.4WEA	25.4	150	82	79	22.1	32	25.4	26.0
BSMSGLO38.1WEA	38.1	158	82	85	34.7	40	38.1	34.0
BSMSGLO50.8WEA	50.8	162	82	105	47.6	60	50.8	50.0
BSMSGLO63.5WEA	63.5	162	82	112	60.2	75	63.5	65.0
BSMSGLO76.2WEA	76.2	164	82	125	72.0	85	76.2	75.4
BSMSGLO101.6WEA	101.6	170	82	157	97.6	110	101.6	100.0
BSMSGLO152.4WEA	152.4	196	82	214	146.8	160	152.4	150.0

Maximum working pressure 10 bar

Replacement Glass Lens	Size
SGLG025.4	25.4
SGLG038.1	38.1
SGLG050.8	50.8
SGLG063.5	63.5
SGLG076.2	76.2
SGLG101.6	101.6
SGLG154.4	152.4

Replacement Glass Lens	Size
SGLP025.4	25.4
SGLP038.1	38.1
SGLP050.8	50.8
SGLP063.5	63.5
SGLP076.2	76.2
SGLP101.6	101.6
SGLP152.4	152.4

Replacement Glass Lens	Size
SGSE025.4	25.4
SGSE038.1	38.1
SGSE050.8	50.8
SGSE063.5	63.5
SGSE076.2	76.2
SGSE101.6	101.6
SGSE152.4	152.4

Sample Valves

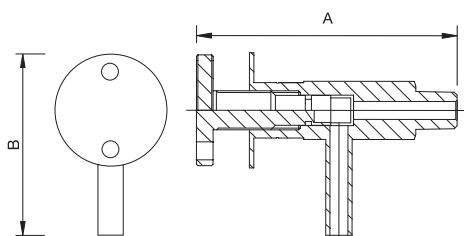

LOCKABLE SAMPLE VALVE 316

Part Number	Size	A	B
VSCL015EA	R15	75	67

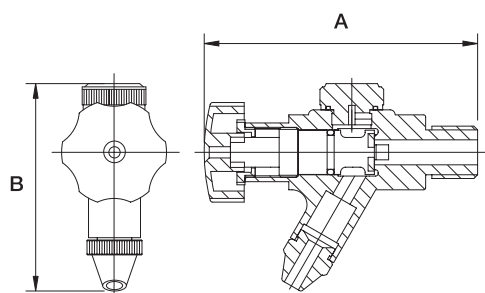

TEST VALVE 316

Part Number	Size	A	B
VWT015EA	G15	109	83

ALL DIMENSIONS ARE IN MILLIMETRES

Stainless Steel Welded Tubing



**WELDED TUBE
PHYSICAL DIMENSIONS AND TEST PRESSURE,
IN ACCORDANCE WITH AS 1528.1 STANDARD**

Outside Diameter Nominal mm	Outside Diameter Tolerance mm	Wall Thickness Nominal mm	Wall Thickness Tolerance mm	Cut Length Tolerance mm	Test Pressure MPa
12.7	± 0.13	1.6	+nil, -0.10	-0, +3	26.9
19.1	± 0.13	1.6	+nil, -0.10	-0, +3	18.0
25.4	± 0.13	1.6	+nil, -0.10	-0, +3	13.5
31.8	± 0.13	1.6	+nil, -0.10	-0, +3	10.8
38.1	± 0.25	1.6	+nil, -0.10	-0, +5	9.0
50.8	± 0.25	1.6	+nil, -0.10	-0, +5	6.7
63.5	± 0.25	1.6	+nil, -0.10	-0, +5	5.4
76.2	± 0.25	1.6	+nil, -0.10	-0, +5	4.5
101.6	± 0.38	1.6	+nil, -0.10	-0, +5	3.4
127.0	± 0.38	1.6	+nil, -0.10	-0, +5	2.7
152.4	± 0.76	1.6	+nil, -0.10	-0, +5	2.2
203.2	± 0.76	2.0	+nil, -0.10	-0, +5	2.2
204.0*	± 2.04	2.0	± 0.20	-0, +10	7.0
254.0*	± 2.54	2.0	± 0.20	-0, +10	7.0
304.8*	± 3.05	2.5	± 0.25	-0, +10	7.0
355.6*	± 3.56	3.0	± 0.30	-0, +10	7.0

* Tubes are manufactured to EN10217-7 - Welded steel tubes for pressure purposes.

Welded Tube – Prochem stock welded tube in a variety of finishes to suit market needs. These include “as welded”, “as welded polished”, “welded bright annealed”, “welded annealed polished”, and others on request. Materials in stock include 304 and 316 stainless steel to ASTM A269, ASTM A554 and AS1528.1, with other grades, standards or sizes available on request.



STAINLESS STEEL ROUND WELDED TUBE 6 METRE LENGTHS

Size, OD		Wall Thickness		Weight kg/m	T304						T316						
mm	inch	mm	Guage		AW	AWP	AWP3	AWA	AWAP	CW	AW	AWP	AWP3	AWM	AWA	AWAP	CWP
12.70	1/2	1.20	18	0.34		•	•					•	•				
12.70	1/2	1.60	16	0.45	•	•	•					•	•				
15.88	5/8	1.60	16	0.60	•	•	•					•	•				
19.10	3/4	1.60	16	0.71	•	•	•					•	•	•			•
22.23	7/8	1.60	16	0.84	•							•	•	•			
25.40	1	1.60	16	0.97	•	•	•					•	•	•			•
31.75	1-1/4	1.60	16	1.23	•	•	•					•	•	•			•
38.10	1-1/2	1.60	16	1.49	•	•	•				•	•	•	•			•
50.80	2	1.60	16	2.09		•	•					•	•	•			•
63.50	2-1/2	1.60	16	2.52	•	•	•					•	•				•
76.20	3	1.60	16	3.04		•	•					•	•				•
101.60	4	1.60	16	4.08	•	•	•					•	•				•
101.60	4	2.03	14	5.23	•	•	•										
127.00	5	1.60	16	5.12	•												
152.40	6	1.60	16	6.15	•	•	•				•	•	•				
152.40	6	2.03	14	7.91	•												
203.20	8	2.03	14	10.44	•						•						
204.00	-	2.0	-		*						*						
254.00	-	2.0	-		*						*						
254.00	10	2.03	14	13.07	•						•						
304.80	-	2.50	-		*						*						
355.6	-	3.00	-								*						

* Tubes are manufactured to EN10217-7 - Welded steel tubes for pressure purposes. Materials 304L and 316L

• STANDARD STOCK

SPIRAL WOUND TUBE AVAILABLE IN CERTAIN SIZES. 152.4 X 1.6 MM & 203.2 X 2.03MM ALSO AVAILABLE IN T316L

STAINLESS STEEL SQUARE TUBE ASTM A554

Size mm	Wall Thickness mm	Weight kg/m	T304 Polished	T316 Polished
12.70 x 12.70	1.2	0.44	•	
19.10 x 19.10	1.2	0.67	•	
19.10 x 19.10	1.6	0.88	•	
25.40 x 25.40	1.2	0.92	•	
25.40 x 25.40	1.6	1.21	•	•
31.75 x 31.75	1.2	1.17	•	
31.75 x 31.75	1.6	1.55	•	
38.10 x 38.10	1.2	1.40	•	
38.10 x 38.10	1.6	1.85	•	•
38.10 x 38.10	3.0	3.30	•	
50.80 x 50.80	1.6	2.49	•	
50.80 x 50.80	3.0	4.48	•	
76.20 x 76.20	3.0	7.30	•	
101.60 x 101.60	3.0	9.73	•	

• STANDARD STOCK

DEFINITIONS

LEGEND

AW	AS WELDED
AWM	AS WELDED POLISHED Mirror
AWP3	AS WELDED POLISHED 320 Grit
AWP	AS WELDED POLISHED 600 Grit
AWA	AS WELDED ANNEALED
AWAP	AS WELDED ANNEALED-POLISHED
CW	COLD WORKED
CWP	COLD WORKED POLISHED

“AW” & “AWP” ARE MANUFACTURED TO ASTM A554

“CW” & “CWP” ARE MANUFACTURED TO AS1528
Tubes of this quality are suitable for use in the food industry.
Available in Grades T304 and T316

“AWA” & “AWAP” ARE MANUFACTURED TO ASTM A269
annealed condition

POLISHED TUBE (all supplied in plastic sleeves)

Our Standard polish is: **Round Tube:** 320 Grit, 600 Grit and Mirror finish
Square Tube: 180 Grit

Flanges

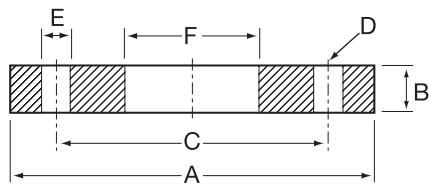
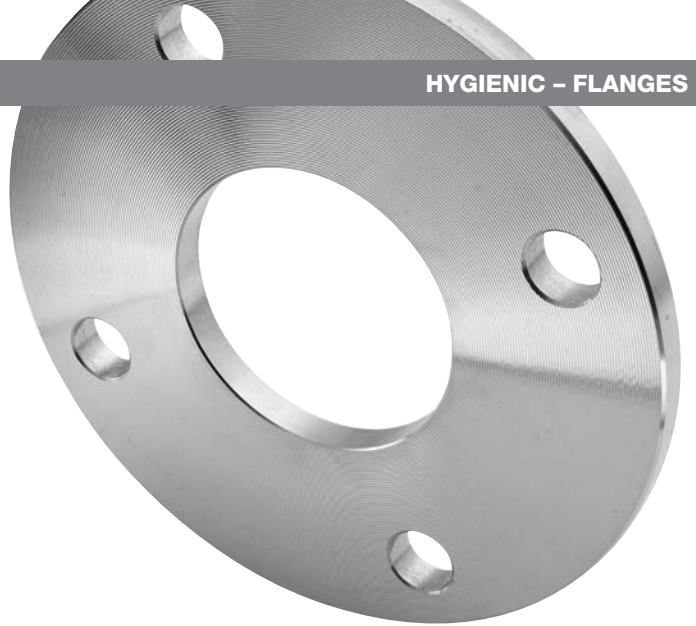

SLIP-ON WELDING

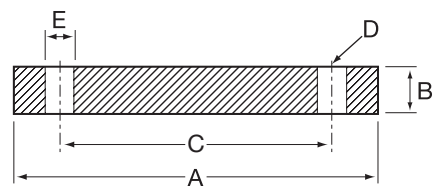

BLIND

TABLE D FLANGES 316L

Part Number for Blind Flange	Part Number for Pipe Bore Slip-On	Part Number for Tube Bore Slip-On	Pipe Size DN	Tube Size OD	Outside Diam. of Flange A	Forged or Plate; Thickness of Flange Min. B	Pitch Circle Diam. C	Number of Holes D	Diam. of Holes E	Diam. of Bolts Metric	Slip-On F
BSD015BLB	BSD015PBSOB	BSD015TBSOB	15	12.70	95	5*	67	4	14	M12	BORE OF FLANGES TO SUIT EITHER PIPE OR TUBE OD - REFER PIPE & TUBE DIMENSIONS ON PAGES 36 & 37
BSD020BLB	BSD020PBSOB	BSD020TBSOB	20	19.10	100	5*	73	4	14	M12	
BSD025BLB	BSD025PBSOB	BSD025TBSOB	25	25.40	115	5*	83	4	14	M12	
BSD032BLB	BSD032PBSOB	BSD032TBSOB	32	31.80	120	6*	87	4	14	M12	
BSD040BLB	BSD040PBSOB	BSD040TBSOB	40	38.10	135	6*	98	4	14	M12	
BSD050BLB	BSD050PBSOB	BSD050TBSOB	50	50.80	150	8*	114	4	18	M16	
BSD065BLB	BSD065PBSOB	BSD065TBSOB	65	63.50	165	8*	127	4	18	M16	
BSD080BLB	BSD080PBSOB	BSD080TBSOB	80	76.20	185	10*	146	4	18	M16	
BSD100BLB	BSD100PBSOB	BSD100TBSOB	100	101.60	215	10*	178	4	18	M16	
BSD125BLB	BSD125PBSOB	BSD125TBSOB	125	127.00	255	13	210	8	18	M16	
BSD150BLB	BSD150PBSOB	BSD150TBSOB	150	152.40	280	13	235	8	18	M16	
BSD200BLB	BSD200PBSOB	BSD200TBSOB	200	203.20	335	13	292	8	18	M16	
BSD250BLB	BSD250PBSOB	BSD250TBSOB	250	254.00	405	16	356	8	22	M20	
BSD300BLB	BSD300PBSOB	BSD300TBSOB	300	304.80	455	19	406	12	22	M20	
BSD350BLB	BSD350PBSOB	BSD350TBSOB	350	355.60	525	22	470	12	26	M24	
BSD400BLB	BSD400PBSOB	BSD400TBSOB	400	406.40	580	22	521	12	26	M24	
BSD450BLB	BSD450PBSOB	BSD450TBSOB	450	457.20	640	25	584	12	26	M24	
BSD500BLB	BSD500PBSOB	BSD500TBSOB	500	508.00	705	29	641	16	26	M24	
BSD600BLB	BSD600PBSOB	BSD600TBSOB	600	609.60	825	32	756	16	30	M27	

* Flanges less than 12 mm thickness may suffer unacceptable distortion after welding to pipe.

304L FLANGES ARE ALSO AVAILABLE. REPLACE THE FINAL “B” IN THE PART NUMBER WITH “D”

NB - 15 NB TO 32 NB ONLY STOCKED IN TABLE ‘E’ FLANGE

ALL SIZES ARE IN MILLIMETRES

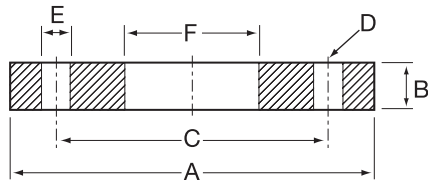

SLIP-ON WELDING

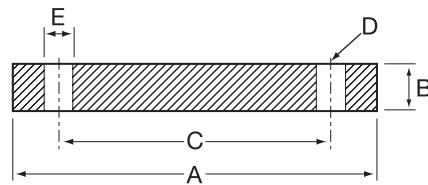

BLIND

TABLE E FLANGES 316L

Part Number for Blind Flange	Part Number for Pipe Bore Slip-On	Part Number for Tube Bore Slip-On	Pipe Size DN	Tube Size OD	Outside Diam. of Flange A	Forged or Plate; Thickness of Flange Min. B	Pitch Circle Diam. C	Number of Holes D	Diam. of Holes E	Diam. of Bolts Metric	Slip-On F
BSE015BLB	BSE015PBSOB	BSE015TBSOB	15	12.70	95	6*	67	4	14	M12	BORE OF FLANGES TO SUIT EITHER PIPE OR TUBE OD - REFER PIPE & TUBE DIMENSIONS ON PAGES 36 & 37
BSE020BLB	BSE020PBSOB	BSE020TBSOB	20	19.10	100	6*	73	4	14	M12	
BSE025BLB	BSE025PBSOB	BSE025TBSOB	25	25.40	115	7*	83	4	14	M12	
BSE032BLB	BSE032PBSOB	BSE032TBSOB	32	31.80	120	8*	87	4	14	M12	
BSE040BLB	BSE040PBSOB	BSE040TBSOB	40	38.10	135	9*	98	4	14	M12	
BSE050BLB	BSE050PBSOB	BSE050TBSOB	50	50.80	150	10*	114	4	18	M16	
BSE065BLB	BSE065PBSOB	BSE065TBSOB	65	63.50	165	10*	127	4	18	M16	
BSE080BLB	BSE080PBSOB	BSE080TBSOB	80	76.20	185	11*	146	4	18	M16	
BSE100BLB	BSE100PBSOB	BSE100TBSOB	100	101.60	215	13	178	8	18	M16	
BSE125BLB	BSE125PBSOB	BSE125TBSOB	125	127.00	255	14	210	8	18	M16	
BSE150BLB	BSE150PBSOB	BSE150TBSOB	150	152.40	280	17	235	8	22	M20	
BSE200BLB	BSE200PBSOB	BSE200TBSOB	200	203.20	335	19	292	8	22	M20	
BSE250BLB	BSE250PBSOB	BSE250TBSOB	250	254.00	405	22	356	12	22	M20	
BSE300BLB	BSE300PBSOB	BSE300TBSOB	300	304.80	455	25	406	12	26	M24	
BSE350BLB	BSE350PBSOB	BSE350TBSOB	350	355.60	525	29	470	12	26	M24	
BSE400BLB	BSE400PBSOB	BSE400TBSOB	400	406.40	580	32	521	12	26	M24	
BSE450BLB	BSE450PBSOB	BSE450TBSOB	450	457.20	640	35	584	16	26	M24	
BSE500BLB	BSE500PBSOB	BSE500TBSOB	500	508.00	705	38	641	16	26	M24	
BSE600BLB	BSE600PBSOB	BSE600TBSOB	600	609.60	825	48	756	16	33	M30	

* Flanges less than 12 mm thickness may suffer unacceptable distortion after welding to pipe.

304L FLANGES ARE ALSO AVAILABLE. REPLACE THE FINAL “B” IN THE PART NUMBER WITH “D”

NB - 15 NB TO 32 NB ONLY STOCKED IN TABLE ‘E’ FLANGE

ALL SIZES ARE IN MILLIMETRES

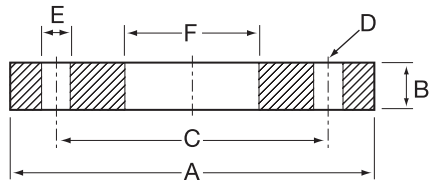

SLIP-ON WELDING

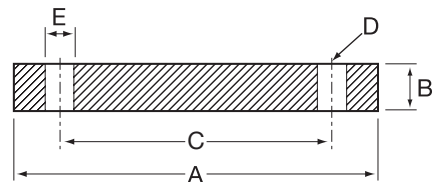

BLIND

TABLE F FLANGES 316L

Part Number for Blind Flange	Part Number for Pipe Bore Slip-On	Part Number for Tube Bore Slip-On	Pipe Size DN	Tube Size OD	Outside Diam. of Flange A	Forged or Plate; Thickness of Flange Min. B	Pitch Circle Diam. C	Number of Holes D	Diam. of Holes E	Diam. of Bolts Metric	Slip-On F
BSF015BLB	BSF015PBSOB	BSF015TBSOB	15	12.70	95	10*	67	4	14	M12	BORE OF FLANGES TO SUIT EITHER PIPE OR TUBE OD - REFER PIPE & TUBE DIMENSIONS ON PAGES 36 & 37
BSF020BLB	BSF020PBSOB	BSF020TBSOB	20	19.10	100	10*	73	4	14	M12	
BSF025BLB	BSF025PBSOB	BSF025TBSOB	25	25.40	120	10*	87	4	18	M16	
BSF032BLB	BSF032PBSOB	BSF032TBSOB	32	31.80	135	13	98	4	18	M16	
BSF040BLB	BSF040PBSOB	BSF040TBSOB	40	38.10	140	13	105	4	18	M16	
BSF050BLB	BSF050PBSOB	BSF050TBSOB	50	50.80	165	16	127	4	18	M16	
BSF065BLB	BSF065PBSOB	BSF065TBSOB	65	63.50	185	16	146	8	18	M16	
BSF080BLB	BSF080PBSOB	BSF080TBSOB	80	76.20	205	16	165	8	18	M16	
BSF100BLB	BSF100PBSOB	BSF100TBSOB	100	101.60	230	19	191	8	18	M16	
BSF125BLB	BSF125PBSOB	BSF125TBSOB	125	127.00	280	22	235	8	22	M20	
BSF150BLB	BSF150PBSOB	BSF150TBSOB	150	152.40	305	22	260	12	22	M20	
BSF200BLB	BSF200PBSOB	BSF200TBSOB	200	203.20	370	25	324	12	22	M20	
BSF250BLB	BSF250PBSOB	BSF250TBSOB	250	254.00	430	29	381	12	26	M24	
BSF300BLB	BSF300PBSOB	BSF300TBSOB	300	304.80	490	32	438	16	26	M24	
BSF350BLB	BSF350PBSOB	BSF350TBSOB	350	355.60	550	35	495	16	30	M27	
BSF400BLB	BSF400PBSOB	BSF400TBSOB	400	406.40	610	41	552	20	30	M27	
BSF450BLB	BSF450PBSOB	BSF450TBSOB	450	457.20	675	44	610	20	33	M30	
BSF500BLB	BSF500PBSOB	BSF500TBSOB	500	508.00	735	51	673	24	33	M30	
BSF600BLB	BSF600PBSOB	BSF600TBSOB	600	609.60	850	57	781	24	36	M33	

* Flanges less than 12 mm thickness may suffer unacceptable distortion after welding to pipe.

304L FLANGES ARE ALSO AVAILABLE. REPLACE THE FINAL “B” IN THE PART NUMBER WITH “D”

NB - 15 NB TO 32 NB ONLY STOCKED IN TABLE ‘E’ FLANGE

ALL SIZES ARE IN MILLIMETRES

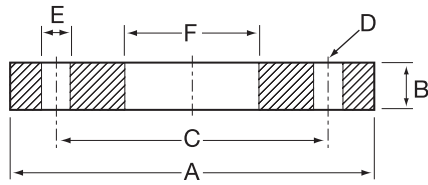

SLIP-ON WELDING

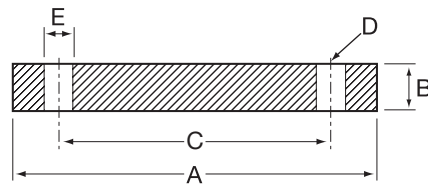

BLIND

TABLE H FLANGES 316L

Part Number for Blind Flange	Part Number for Pipe Bore Slip-On	Part Number for Tube Bore Slip-On	Pipe Size DN	Tube Size OD	Outside Diam. of Flange A	Forged or Plate; Thickness of Flange Min. B	Pitch Circle Diam. C	Number of Holes D	Diam. of Holes E	Diam. of Bolts Metric	Slip-On F
BSH015BLB	BSH015PBSOB	BSH015TBSOB	15	12.70	115	13	83	4	18	M16	BORE OF FLANGES TO SUIT EITHER PIPE OR TUBE OD - REFER PIPE & TUBE DIMENSIONS ON PAGES 36 & 37
BSH020BLB	BSH020PBSOB	BSH020TBSOB	20	19.10	115	13	83	4	18	M16	
BSH025BLB	BSH025PBSOB	BSH025TBSOB	25	25.40	120	14	87	4	18	M16	
BSH032BLB	BSH032PBSOB	BSH032TBSOB	32	31.80	135	17	98	4	18	M16	
BSH040BLB	BSH040PBSOB	BSH040TBSOB	40	38.10	140	17	105	4	18	M16	
BSH050BLB	BSH050PBSOB	BSH050TBSOB	50	50.80	165	19	127	4	18	M16	
BSH065BLB	BSH065PBSOB	BSH065TBSOB	65	63.50	185	19	146	8	18	M16	
BSH080BLB	BSH080PBSOB	BSH080TBSOB	80	76.20	205	22	165	8	18	M16	
BSH100BLB	BSH100PBSOB	BSH100TBSOB	100	101.60	230	25	191	8	18	M16	
BSH125BLB	BSH125PBSOB	BSH125TBSOB	125	127.00	280	29	235	8	22	M20	
BSH150BLB	BSH150PBSOB	BSH150TBSOB	150	152.40	305	29	260	12	22	M20	
BSH200BLB	BSH200PBSOB	BSH200TBSOB	200	203.20	370	32	324	12	22	M20	
BSH250BLB	BSH250PBSOB	BSH250TBSOB	250	254.00	430	35	381	12	26	M24	
BSH300BLB	BSH300PBSOB	BSH300TBSOB	300	304.80	490	41	438	16	26	M24	
BSH350BLB	BSH350PBSOB	BSH350TBSOB	350	355.60	550	48	495	16	30	M27	
BSH400BLB	BSH400PBSOB	BSH400TBSOB	400	406.40	610	54	552	20	30	M27	
BSH450BLB	BSH450PBSOB	BSH450TBSOB	450	457.20	675	60	610	20	33	M30	
BSH500BLB	BSH500PBSOB	BSH500TBSOB	500	508.00	735	67	673	24	33	M30	
BSH600BLB	BSH600PBSOB	BSH600TBSOB	600	609.60	850	76	781	24	36	M33	

304L FLANGES ARE ALSO AVAILABLE. REPLACE THE FINAL "B" IN THE PART NUMBER WITH "D"

NB - 15 NB TO 32 NB ONLY STOCKED IN TABLE 'E' FLANGE

ALL SIZES ARE IN MILLIMETRES



FOR FURTHER DETAILS PLEASE CONTACT YOUR LOCAL PROCHEM OFFICE

ADELAIDE

3A CB Fisher Drive, CAVAN
South Australia
Australia 5094
Telephone 61-8-8241 7633
Facsimile 61-8-8241 7644
Email sales@prochem.com.au

HOBART

96-98 Central Avenue
Derwent Park, Tasmania
Australia 7009
Telephone 61-3-6272 8828
Facsimile 61-3-6272 8688
Email sales@prochem.com.au

PERTH

6 Forge Street
Welshpool, Western Australia
Australia 6106
Telephone 61-8-9458 7777
Facsimile 61-8-9351 8170
Email sales@prochem.com.au

BRISBANE

1-5 Kingsbury Street
Brendale, Queensland
Australia 4500
Telephone 61-7-3265 2711
Facsimile 61-7-3265 7430
Email sales@prochem.com.au

MELBOURNE

5-15 Ventura Place
Dandenong South, Victoria
Australia 3175
Telephone 61-3-9799 2244
Facsimile 61-3-9799 2255
Email sales@prochem.com.au

SYDNEY

30 Enterprise Circuit
Prestons, New South Wales
Australia 2170
Telephone 61-2-9727 0044
Facsimile 61-2-9728 6766
Email sales@prochem.com.au

www.prochem.com.au | [1300 287 777](tel:1300287777) | sales@prochem.com.au